

VALMATIC®

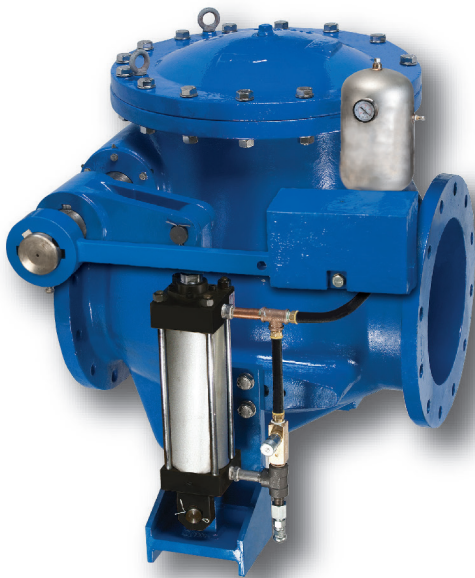

AWWA Swing Check Valve



www.valmatic.com

NSF/ANSI 61 & 372 Certified

Feature Highlights

Series 7800

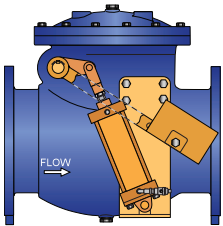

Air Cushion

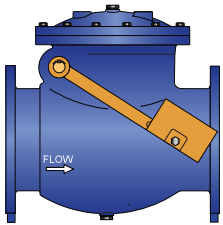

Lever & Weight

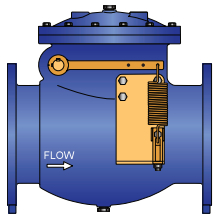

Lever & Spring

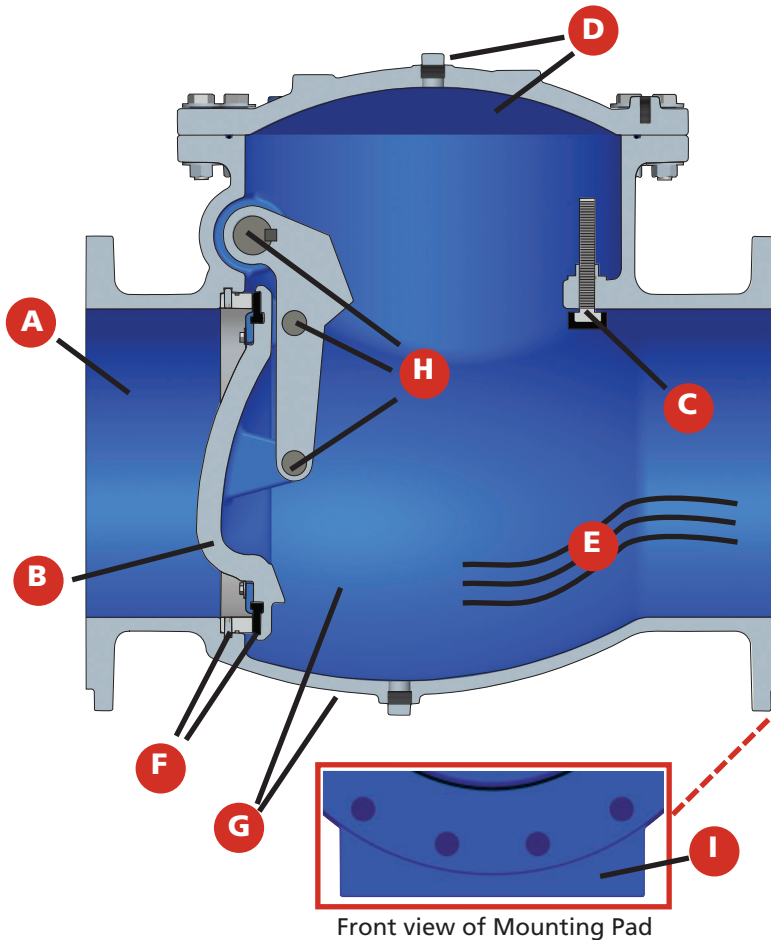

Front view of Mounting Pad

Series 7900

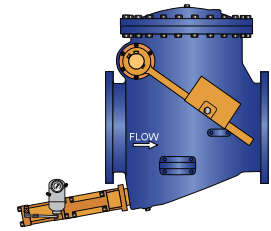

Bottom Oil Cushion

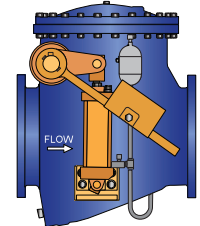

2-Stage Side Oil Cushion

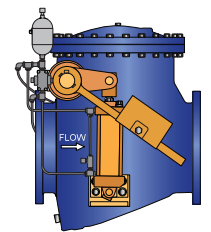

3-Stage Side Oil Cushion

A. 100% Flow Area

Energy savings provided with 100% unrestricted flow area.

B. Disc Stabilization

The fluid dynamic convex disc provides for lift, stabilization and strength.

C. Adjustable Stop

Adjustable resilient open stop to prevent disc flutter for applications outside the typical flow ranges.

D. Full Domed Access Cover with Vent Port

Full domed access cover allows for ease of maintenance without removing the valve from the line. The vent port allows the addition of an air release valve or pressure gauge.

E. Non-Clog Design

The unrestricted full flow area combined with smooth streamline

contouring allows for passage of large solids to prevent potential clogging.

F. Seating Options

The field replaceable synthetic seat, with integral O-ring, assures positive seating at high and low pressures. Body seats are stainless steel to extend the life of the valve and are also field replaceable.

When operating conditions require a metal-to-metal seat, the disc is fitted with a precision machined aluminum bronze seating surface. The disc seat seals against the field replaceable aluminum bronze body seat for reliable operation under harsh conditions.

G. Fusion Bonded Epoxy

Fusion Bonded Epoxy (FBE) is provided standard on the interior and exterior of the valve. The FBE is NSF/ANSI 61 certified and complies with AWWA C550.

H. Heavy Duty Disc Connections

Heavy duty shaft and disc retaining pins constructed of high tensile stainless steel for superior strength, wear resistance and extended life.

I. Mounting Pads

Integral mounting pads provide vertical support for ease of installation. The pads are integral to both flanges and are standard on Series 7800 valves. When necessary for installation, mounting pads can be provided on Series 7900 valves.

J. Closure Versatility

The Series 7800 AWWA Swing Check Valve is available with multiple field adjustable closure options: Air Cushion, Lever & Weight and Lever & Spring. The Series 7900 is available with either bottom or side oil cushions.

Feature Benefits

Proven Design

The Val-Matic Swing Check Valve incorporates many design features and characteristics that will provide energy savings, ease of maintenance and extended valve life. The valve is designed for municipal and industrial water and wastewater applications and fully complies with ANSI/AWWA C508 and MSS SP-71/MSS SP-136.

Closure Versatility

7800 Air Cushion, Lever & Weight, Lever & Spring

The Series 7800 Swing Check Valves can be supplied with Air Cushion, Lever & Weight or Lever & Spring for control of the disc closure. The Lever & Weight or Lever & Spring designs are suitable for installation in horizontal or vertical pipelines and are easily adjustable in the field. When rapid flow reversal occurs, the Swing Check Valves can be supplied with dual lever arms, weights and springs. A fully enclosed and adjustable Air Cushion can be added to the standard Lever & Weight to control valve operation and reduce water hammer.

7900 Oil Cushion

The Series 7900 Swing Check Valves include single or dual lever arms with weights and are equipped with either side or bottom oil cushions. The bottom oil cushion provides adjustable control of the final 10% of disc closure. The side oil cushion allows for independent adjustment of closure speeds in either 2- or 3- stages.

Ductile Iron Construction

Val-Matic provides standard Swing Check Valves with ductile iron construction rated to 250 psig Cold Working Pressure (CWP). Ductile iron provides greater strength and toughness than conventional gray iron materials. With ductile iron construction, the body, disc, and disc arm can safely withstand high stresses and shock loads.

Seating System

Val-Matic Swing Check Valves are offered with either drop-tight resilient seating or aluminum bronze metal seating.

Resilient Seating System

For resilient seated valves, the body is fitted with a 300 series stainless steel seat that is raised from the body to assure sealing in applications with high solids. A molded resilient seat mounted on the disc has integral O-ring sealing surfaces for drop tight sealing at high and low pressures. Both seats are secured with stainless steel fasteners and are field replaceable without removing the valve from the line. (See Figure 1)

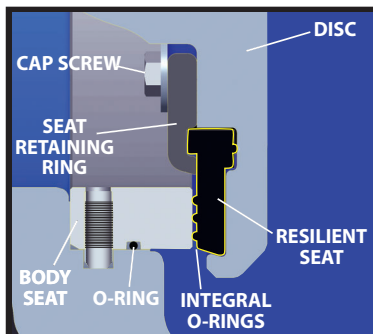

Figure 1 - Resilient Seating System

Metal Seating System

For metal seated valves, the body is fitted with an aluminum bronze seat secured to the body. The body seat mates with a second aluminum bronze seat integral with the disc. (See Figure 2)

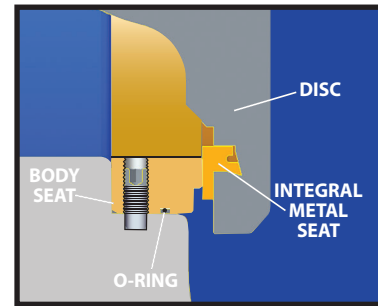

Figure 2 - Metal Seating System

Shaft Seal System

V-Type Packing

The Series 7800 Swing Check Valves are designed with an enhanced V-Type packing system to prevent overload of the packing, the most common reason for packing leakage and failure. To prevent the packing from being over tightened, the shaft seal incorporates POPT™ (Packing Overload Protection) Shims with pull tabs. Adjustment is easily accomplished by removing shims as necessary utilizing the pull tab feature. (See Figure 3)

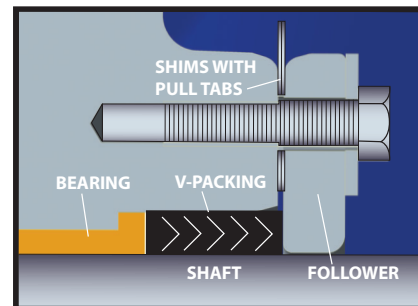

Figure 3 - Series 7800 Shaft Seal System V-Packing

O-ring Cartridge

The Series 7900 Swing Check Valves are designed with dual O-ring seals contained in a corrosion resistant cartridge to provide low torque during operation. (See Figure 4)

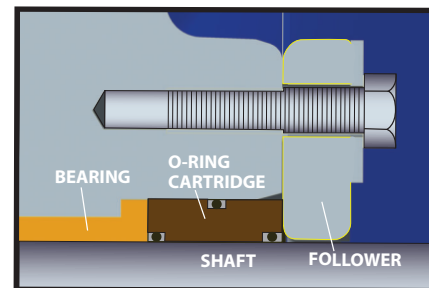

Figure 4 - Series 7900 Shaft Seal System O-ring Cartridge

Corrosion Resistance

The body and disc are fully encapsulated with NSF/ANSI 61 certified fusion bonded epoxy per AWWA C550 to prevent corrosion and provide extended service life. The shaft, disc pins, and seat hardware are constructed of stainless steel for maximum corrosion resistance even in severe service. Lead-Free Bronze bushings are provided in the body to provide smooth and reliable disc closure.

Installation Dimensions

Series 7800AC
Air Cushion

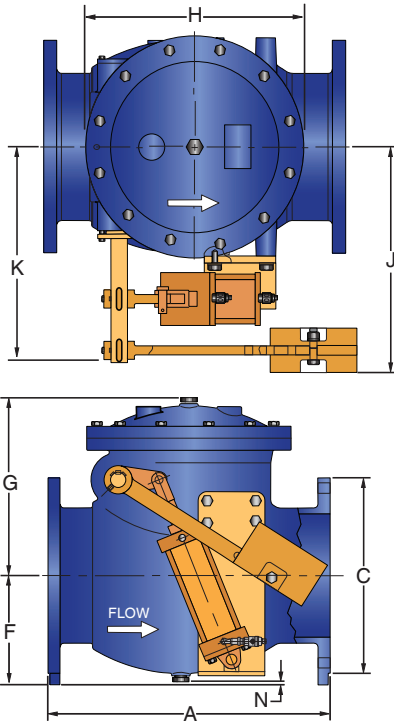

Series 7800LW
Lever & Weight

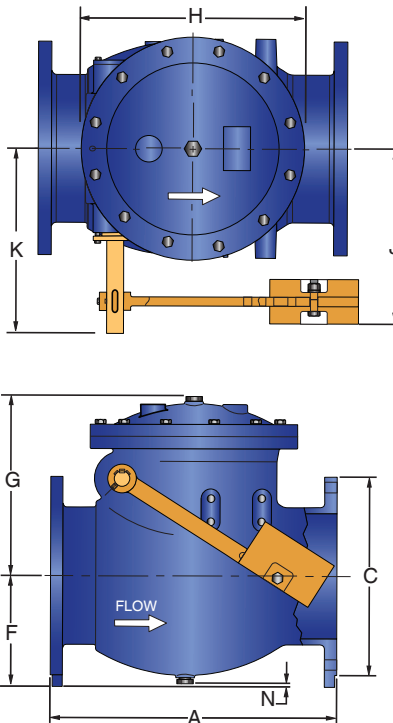

Series 7800LS
Lever & Spring

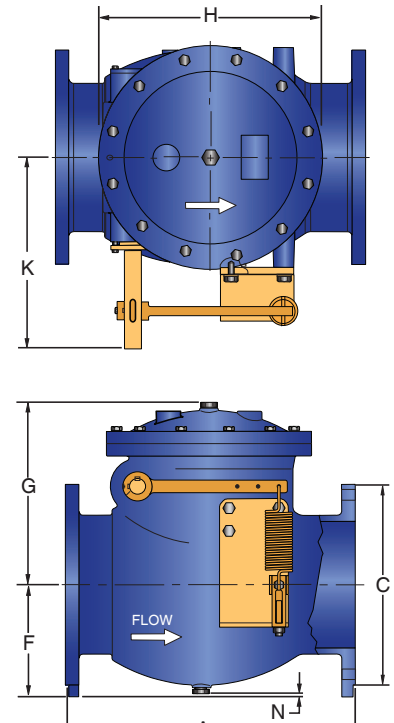

Flanges drilled to ASME B16.1 Class 125 and B16.42 Class 150

Dimensions in Inches

Valve Size	CWP (psig)	A	C	F	G	H	J	K	N*	AC Valve Weights (lbs)	LW Valve Weights (lbs)	LS Valve Weights (lbs)
2	250	8.00	6.00	3.00	4.34	5.39	5.25	2.00	0.27	-	28	26
2 1/2	250	8.50	7.00	3.50	4.34	5.78	7.00	2.50	0.62	-	37	34
3	250	9.50	7.50	3.17	6.69	7.01	7.38	6.97	0.46	65	55	51
4	250	11.50	9.00	4.92	7.60	7.87	8.63	8.23	0.43	105	90	79
6	250	14.00	11.00	6.69	10.53	12.60	12.50	12.22	0.59	205	185	169
8	250	19.50	13.50	8.46	12.80	15.75	15.75	15.16	0.97	351	326	286
10	250	24.50	16.00	8.66	14.33	17.52	17.38	16.61	-0.13	519	484	440
12	250	27.50	19.00	10.63	17.32	19.88	17.88	17.32	0.30	763	723	669
14	250	31.00	21.00	12.50	19.96	23.88	23.13	22.63	-0.04	1061	1011	958
16	250	36.00	23.50	13.75	21.22	26.50	25.00	24.25	-0.29	1227	1177	1101
18	250	40.00	25.00	15.00	23.22	27.88	26.38	25.63	-0.16	1571	1521	1431
20	250	40.00	27.50	16.00	24.94	30.44	28.25	27.50	-0.66	1940	1890	1764
24	250	48.00	32.00	18.50	30.34	36.63	32.75	32.13	0.90	3112	3052	2837
30	150	60.00	38.75	22.00	38.47	43.81	40.75	39.81	-0.87	6148	6088	5708
	250											
36	150	63.00	46.00	25.50	43.22	51.41	45.06	43.81	-1.89	8555	8495	8037
	250											
42	150	70.00	53.00	29.25	49.80	59.88	50.00	48.50	-2.38	11460	11380	10680
	250											
48	150	76.00	59.50	32.75	56.38	68.38	55.13	53.00	-2.63	16860	16780	15940
	250											

*Dimension "N" with negative numbers extend past bottom of integral mounting pads (flange feet).

Installation Dimensions

Series 7900B
Bottom Oil Cushion

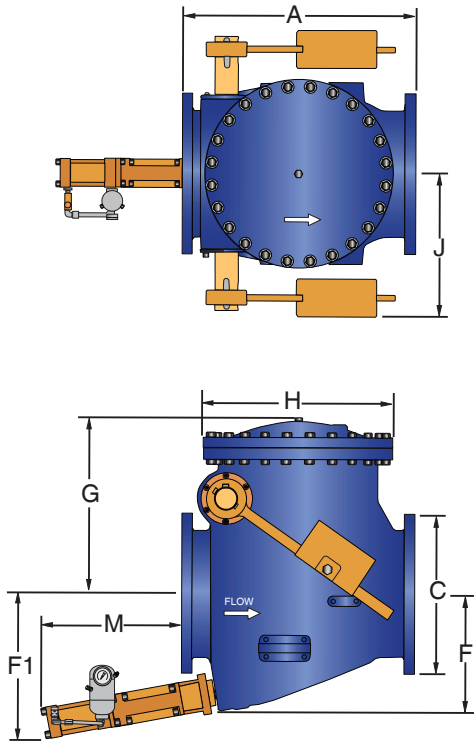

Series 7900S2
2-Stage
Side Oil Cushion

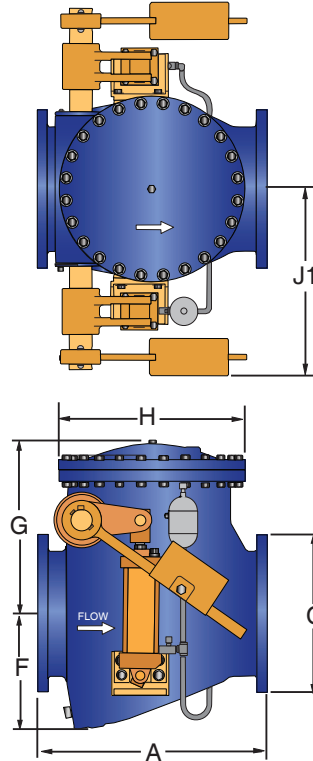

Series 7900S3
3-Stage
Side Oil Cushion

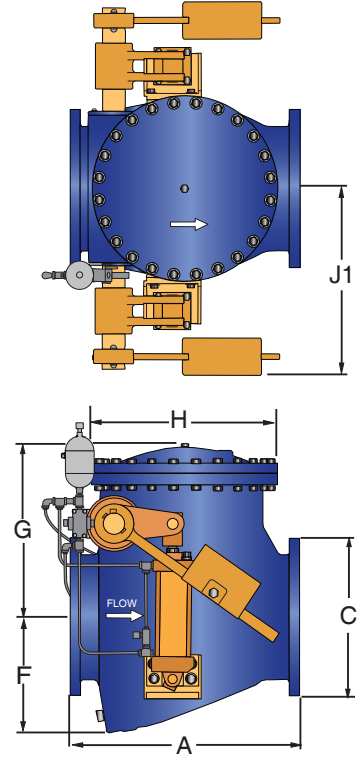

Flanges drilled to ASME B16.42 Class 150

Dimensions in Inches

Valve Size*	CWP (psig)	A	C	F	F1	G	H	J Typ.	J1 Typ.	M	Bottom Valve Weights (lbs)	Side Valve Weights (lbs)
8	200	19.50	13.50	11.25	12.75	15.50	16.50	13.25	18.00	13.50	450	650
10	200	24.50	16.00	13.38	15.13	17.75	19.75	14.25	20.00	15.00	675	980
12	200	27.50	19.00	14.56	16.44	20.16	22.63	16.13	22.00	14.13	960	1400
14	150	31.00	21.00	17.06	20.00	22.25	25.38	19.50	26.57	18.50	1064	1780
16	150	36.00	23.50	18.38	21.25	25.69	28.31	21.75	28.75	17.00	1253	2450
18	150	40.00	25.00	19.25	23.06	28.00	30.88	23.13	31.13	20.63	1521	3130
20	150	40.00	27.50	20.50	24.25	30.25	32.50	24.63	32.63	21.50	1890	3625
24	150	48.00	32.00	24.88	28.50	36.25	38.75	29.50	39.50	24.38	3052	6100
30	150	60.00	38.75	29.50	34.06	38.50	43.81	32.00	-	26.56	5514	-
36	150	63.00	46.00	32.25	38.00	43.25	51.40	36.50	-	35.00	8151	-
42	150	70.00	53.00	35.13	41.25	43.75	60.00	39.00	-	41.25	11380	-
48	150	76.00	59.50	39.00	45.81	56.38	68.38	44.00	-	47.50	16780	-

*Valve Sizes 8"-12" only have a single lever and weight.

Principle of Operation

Oil Cushion Valves

The Series 7900 Oil Cushion Swing Check Valves are ideal in any number of installation configurations including single or multiple pump systems to reduce slamming and reduce system pressure surges. The Series 7900 Check Valve is offered with optional bottom or side oil cushions to aid in disc closure in pump systems even after a power failure. The oil cushions include high pressure hydraulic oil cylinders, flow control valves, and full-rated disc connections. With oil cushions, the movement of the disc is precisely controlled. An adjustable flow control valve regulates the flow of hydraulic oil out of the cylinder, which in-turn controls movement of the disc closure.

Series 7900B Bottom Oil Cushion

In high pressure applications where rapid flow reversals are expected, the last 10% of closure can be controlled to prevent slamming by using a Bottom Oil Cushion consisting of a hydraulic cylinder and snubber rod that contacts the valve disc near the end of travel. When there is flow through the valve, the valve disc lifts off of the snubber rod and opens normally as the flow rate increases. When the valve is open, the air pressure in the accumulator extends the cylinder which pushes the snubber rod into the valve body. When flow stops, the disc closes rapidly through 90% of its travel and then strikes the snubber rod. The last 10% of closure is then controlled in 1-3 seconds by the hydraulic cylinder as the oil flow is metered through the adjustable flow control valve.

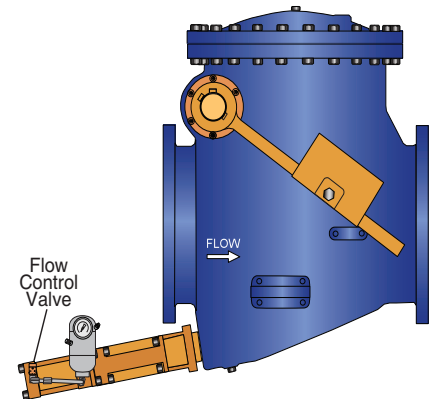

Series 7900S2 2-Stage Side Oil Cushion

When control of the full valve closure is desired to reduce system surges, a 2-Stage Oil Cushion can be used consisting of a high pressure hydraulic cylinder and lever that is directly attached to the shaft. When there is flow through the valve, the valve opens normally while the shaft lever extends the cylinder. When flow stops, the lever contracts the cylinder and the speed of closure is controlled in 5-30 seconds by the oil flow through the adjustable flow control valve for Stage 1. During the last 10% of travel, the closure is controlled in 1-3 seconds using the internal cylinder cushion adjustment for Stage 2.

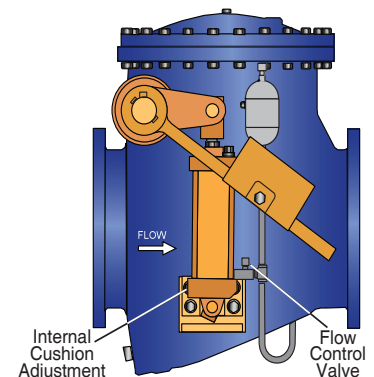

Series 7900S3 3-Stage Side Oil Cushion

For long pipelines, when control of full valve travel is desired in multiple stages, a 3-Stage Oil Cushion can be used to control the closing speed of the Check Valve at three rates. The 3-Stage Oil Cushion consists of a high pressure hydraulic cylinder, a lever that is directly attached to the shaft, and a cam-operated 2-way directional valve that is used to direct flow to a flow control valve. When there is a flow through the Check Valve, the valve opens normally while the hinge pin lever extends the cylinder. When flow stops, the Check Valve closes rapidly while the lever contracts the cylinder for Stage 1. When the valve travels to the 50% position (adjustable), the 2-way valve closes, and the oil flow from the cylinder is directed through the adjustable flow control valve in 5-30 seconds for Stage 2. During the last 10% of travel, the closure is controlled in 1-3 seconds using the internal cylinder cushion adjustment for Stage 3.

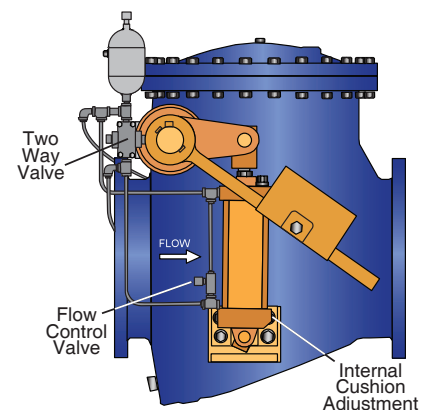

Application Chart

A variety of closure mechanisms allows selection of the correct Swing Check Valve for every application. This application chart illustrates the range of use for the various Swing Check Valve configurations.

Pumping systems with low static head and gradual pipeline flow deceleration may be best served by a conventional lever & weight or air cushion Swing Check. Higher static head applications benefit from a rapid spring assisted closure. When severe deceleration is present in a pumping system, oil cushioned closure provides an economical and reliable means of preventing surges associated with transients while greatly minimizing the potential for check valve slam. The adjustability of closure times on oil cushion Swing Check Valves allows operation to be tailored for each application.

RECOMMENDED VALVE SELECTION

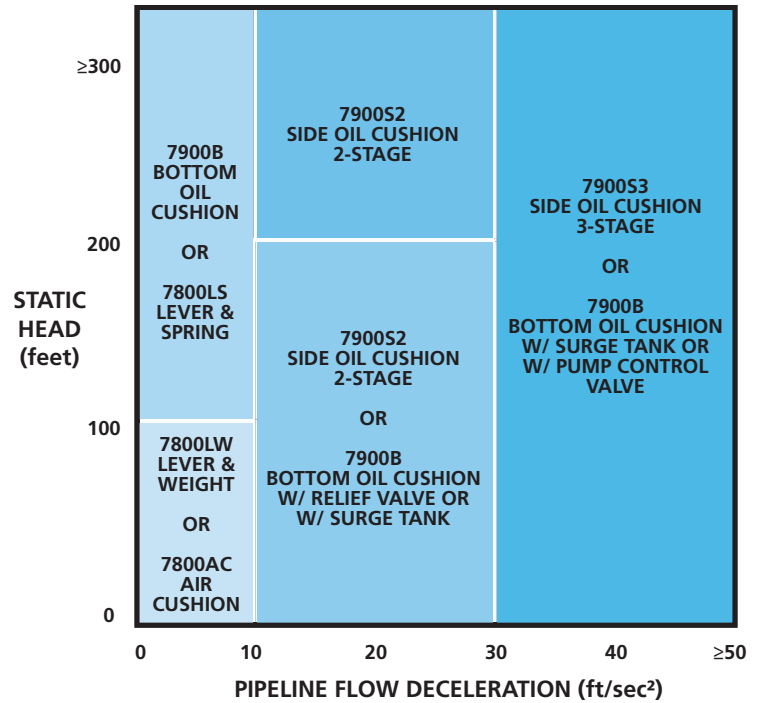

Headloss Chart

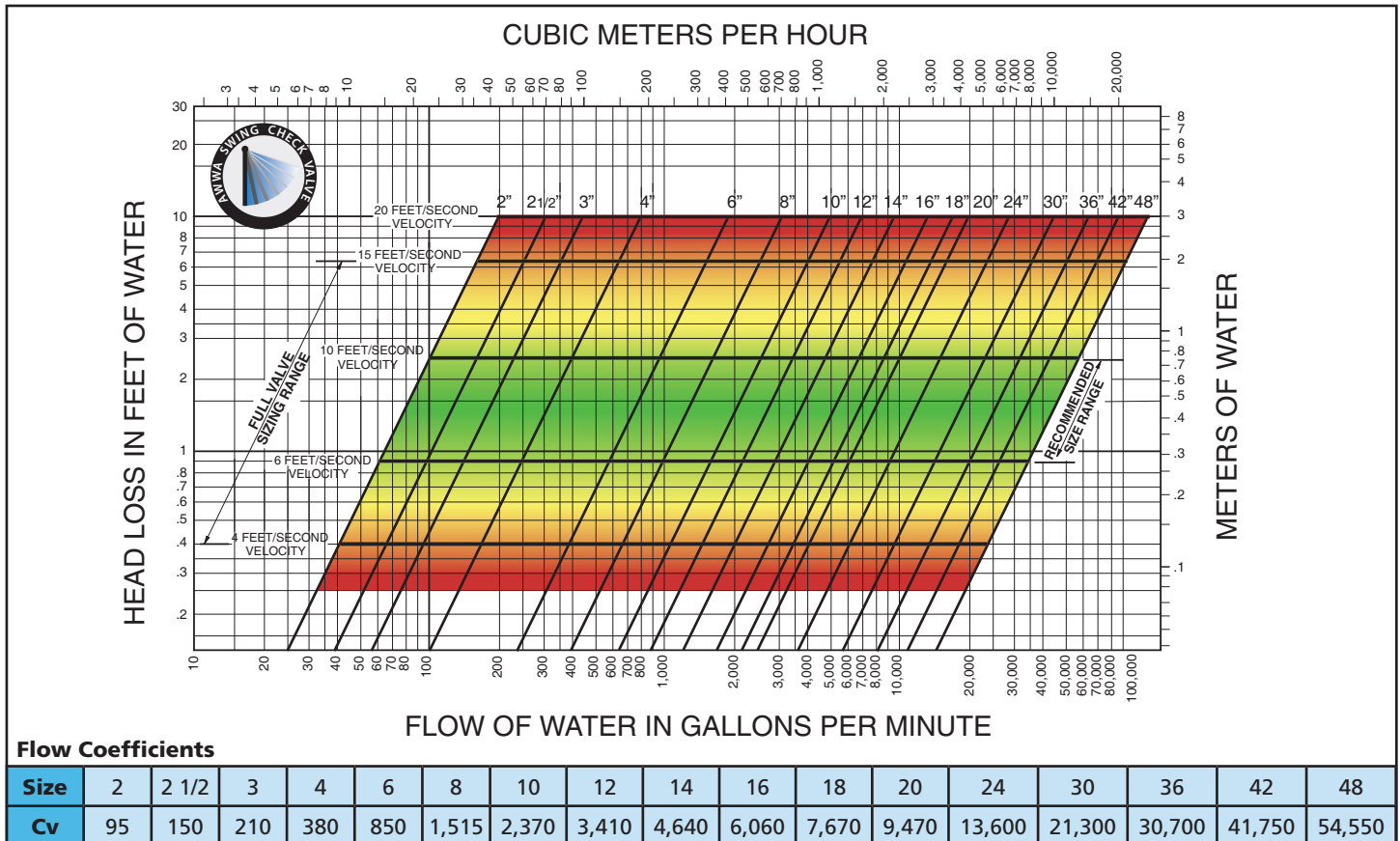

Pressure Ratings

MAXIMUM PRESSURE RATINGS				
SERIES	DESCRIPTION	SIZE RANGE	FLANGE CONNECTION	CWP (psig)
7800AC	Air Cushion	3" - 48"	Class 150 Ductile Iron	250
7800LW	Lever & Weight	2" - 48"		
7800LS	Lever & Spring	2" - 48"		

MAXIMUM PRESSURE RATINGS				
SERIES	DESCRIPTION	SIZE RANGE	FLANGE CONNECTION	CWP (psig)
7900B	Lever & Weight Bottom Oil Cushion	8" - 12"	Class 150 Ductile Iron	200
		14" - 48"		150
7900S	Lever & Weight Side Oil Cushion	8" - 12"	Class 150 Ductile Iron	200
		14" - 24"		150

Materials of Construction

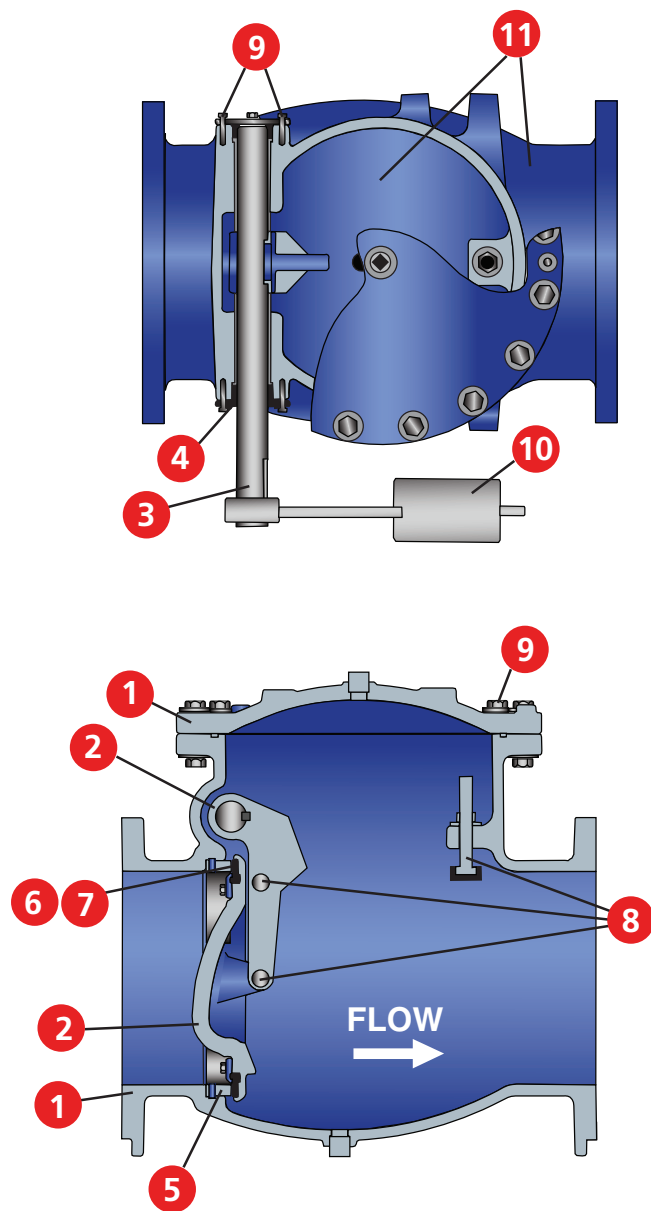

ASSY NO.	COMPONENT	STANDARD	OPTIONAL
1	7800 Body and Cover 2" - 48"	Ductile Iron ASTM A536 Gr 65-45-12	N/A
	7900 Body and Cover 8" - 48"	Ductile Iron ASTM A536 Gr 65-45-12	N/A
2	Disc and Arm	Ductile Iron ASTM A536 Gr 65-45-12	N/A
3	7800 Shaft	T304 Stainless Steel	N/A
	7900 Shaft	T630 Stainless Steel	N/A
4	7800 Shaft Seal	V-Packing Buna-N	N/A
	7900 Shaft Seal	O-ring Buna-N	N/A
5	Removable Body Seat	Stainless Steel ASTM A276 Type 304 or Aluminum Bronze C95400	N/A
6	Molded Resilient Seat	Buna-N	EPDM
7	Metal Integral Seat	Aluminum Bronze C95400	N/A
8	7800 Internal Hardware	T304 Stainless Steel	T316 Stainless Steel
	7900 Internal Hardware	T630 Stainless Steel	T316 Stainless Steel
9	External Hardware 2" - 12"	T304 Stainless Steel	T316 Stainless Steel
	External Hardware 14" - 48"	Alloy Steel, Plated	T316 Stainless Steel
10	External Lever(s)	Ductile Iron ASTM A536 Gr 65-45-12	N/A
11	Internal/External Coating System	Fusion Bonded Epoxy NSF/ANSI 61	N/A

Accessories/Options

Limit Switch

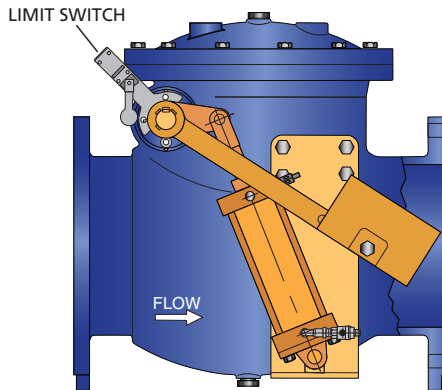

Limit Switch available to indicate open and/or closed valve position for offsite monitoring.

Air Valve Vent & Drain Valve

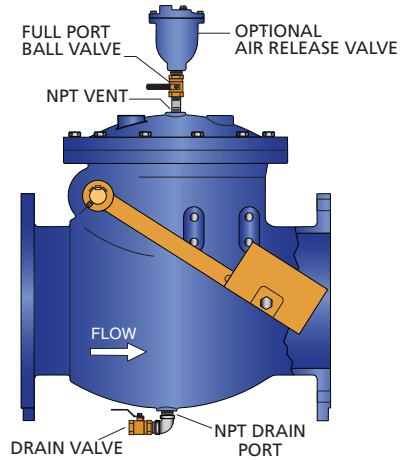

An air release valve prevents the collection of air in the valve and downstream piping to prevent water hammer and system flow restrictions. The drain facilitates maintenance and the removal of silt.

Reverse Mount

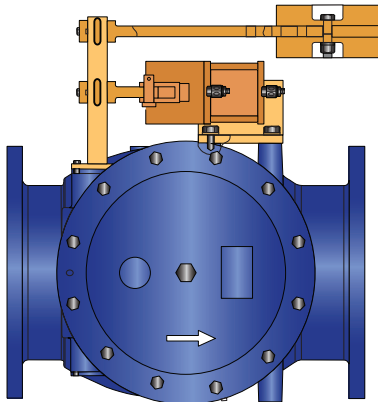

Reverse mount is used to accommodate specific field conditions.

Vertical Installation

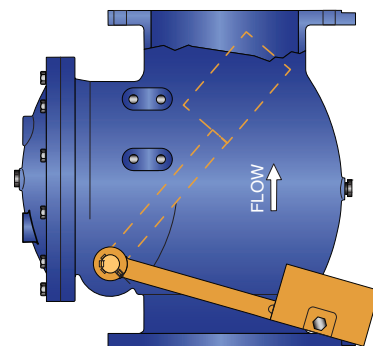

Vertical installation can accommodate specific field conditions and flow up applications.

Safety Guard

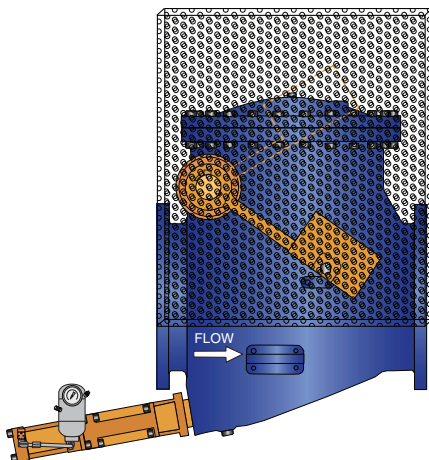

The Safety Guard meets OSHA requirements and can be supplied for all lever weight and cushion assemblies.

Dual Weights

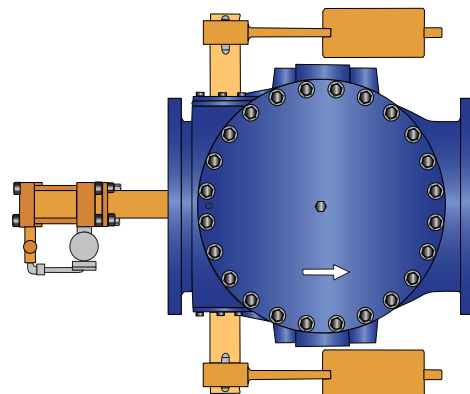

Dual weights are available to provide rapid closure.

Series 7800 Specification

SCOPE

- 1.1 This specification covers the design, manufacture, and testing of 2 in. (50 mm) through 48 in. (1200 mm) Swing Check Valves suitable for cold working pressures of 250 psig.
- 1.2 The check valve shall be of the full flow body type, with a domed access cover and vent port.
- 1.3 The check valve shall be capable of accepting air cushion, lever and weight or lever and spring.

STANDARDS AND APPROVALS

- 2.1 The valves shall be designed, manufactured and tested in accordance with American Water Works Association Standard ANSI/AWWA C508 and in accordance with Manufacturers Standardization Society Standard Practice MSS SP-71 or MSS SP-136.
- 2.2 The valves used in potable water service shall be certified to NSF/ANSI 61, Drinking Water System Components – Health Effects, and certified to be Lead-Free in accordance with NSF/ANSI 372.
- 2.3 Manufacturer shall have a quality management system that is certified to ISO 9001 by an accredited, certifying body.

CONNECTIONS

- 3.1 The Valves shall be provided with flanges drilled in accordance with ASME B16.1, Class 125 iron flanges or ASME B16.42, Class 150 for ductile iron flanges.

DESIGN

- 4.1 The valve body shall be full flow equal to nominal pipe diameter at all points through the valve and shall be equipped with a threaded adjustable open stop. The body seat shall be O-ring sealed and field replaceable without removing the valve from the line. The end flanges shall contain integrally cast mounting pads.
- 4.2 The top access port shall be full size, allowing removal of the disc without removing the valve from the line. The access cover shall be domed in shape to provide flushing action over the disc for operating in lines containing high solids content.
- 4.3 The disc shall be of one-piece construction and connected to the shaft with a disc arm and two pivot pins to provide pivot action to allow self-adjusting seating at all pressures. 14" and larger discs shall be convex shape for lift, stabilization and strength.
- 4.4 When specified, the disc seat shall be resilient with integral O-ring type sealing surface for drop tight shut-off at high and low pressures and for easy replacement in the field without removing the valve from the line.
- 4.5 When specified, metal seated valves shall have aluminum bronze seats.
- 4.6 The shaft seals shall consist of V-type packing in a fixed gland with an adjustable follower designed to prevent over compression of the packing and to meet design parameters of the packing manufacturer. Removable, slotted shims shall be provided under the follower flanges to provide for adjustment and prevent over loading of the packing.

- 4.7 When specified, the valve shall be factory equipped with a lever and weight assembly. The lever shall be equipped with three holes for adjusting the bolted weight assembly. When the valve is closed, the lever and weight shall be located 30 degrees below horizontal.
- 4.8 When specified, the valve shall be factory equipped with a lever and air cushion assembly mounted between the weight assembly and the valve body. The air cushion assembly shall consist of a clevis mounted tie-rod type closed cylinder with speed control valves.
- 4.9 When specified, the valve shall be factory equipped with a lever and spring assembly. The spring shall be mounted to a bracket on the side of the valve body with a bolt assembly to adjust the spring tension.

MATERIALS

- 5.1 The valve body, cover and disc shall be constructed of ASTM A536 Grade 65-45-12 ductile iron.
- 5.2 The exterior and interior of the valve shall be coated with an NSF/ANSI 61 approved fusion bonded epoxy coating.
- 5.3 The removable body seat shall be constructed of ASTM A276, Type 304 stainless steel.
- 5.4 The removable resilient seat shall be precision molded Buna-N (NBR), ASTM D2000-BG. When specified, optional seat material includes EPDM.
- 5.5 The disc, arm, and external levers shall be ductile iron.

OPTIONS

- 6.1 A pre-wired limit switch shall be provided (when specified) to indicate open/closed position to a remote location. The mechanical type limit switch shall be activated by the external arm and rated for NEMA 4, 6, or 6P and shall have U.L. rated 5 amp, 125 or 250 VAC contacts.
- 6.2 When specified, the lever and weight assembly shall be enclosed within a removable safety guard constructed of perforated metal for visibility.

MANUFACTURE

- 7.1 Manufacturer shall demonstrate a minimum of five (5) years' experience in the manufacture of swing check valves.
- 7.2 All valves shall be hydrostatically and seat tested per AWWA C508 to demonstrate leakage criteria and structural integrity. When requested, the manufacturer shall provide test certificates, dimensional drawings, parts list drawings, and operation and maintenance manuals.
- 7.3 Swing Check Valves shall be Series 7800 (resilient seated) or 7800M (metal seated) and equipped with AC (air cushion), LW (lever and weight), or LS (lever and spring) as manufactured by Val-Matic® Valve & Mfg. Corporation, Elmhurst, IL USA or approved equal.

Series 7900 Specification

SCOPE

- 1.1 This specification covers the design, manufacture, and testing of 8 in. (200 mm) through 48 in. (1200 mm) Swing Check Valves suitable for water and wastewater service.
- 1.2 The Cold Working Pressure rating of the valves shall be 200 psig for 8 in. (200 mm) to 12 in. (300 mm) sizes and 150 psig for 14 in. (350 mm) and larger.
- 1.3 The Swing Check Valve shall be of the full waterway body type, with a drain port and domed access cover with vent port.
- 1.4 A Bottom Oil Cushion with Lever and Weight shall be provided on sizes 8 in. (200 mm) to 48 in. (1200 mm) when specified.
- 1.5 A 2-Stage or 3-Stage Side Oil Cushion and Lever and Weight shall be provided on sizes 8 in. (200 mm) to 24 in. (600 mm) when specified.

STANDARDS AND APPROVALS

- 2.1 The valves shall be designed, manufactured and tested in accordance with American Water Works Association Standard ANSI/AWWA C508 and in accordance with Manufacturers Standardization Society Standard Practice MSS SP-136.
- 2.2 The valves used in potable water service shall be certified to NSF/ANSI 61, Drinking Water System Components - Health Effects, and certified to be Lead-Free in accordance with NSF/ANSI 372.
- 2.3 Manufacturer shall have a quality management system that is certified to ISO 9001 by an accredited, certifying body.

CONNECTIONS

- 3.1 The Valves shall be provided with flanges drilled in accordance with ASME B16.42, Class 150 for ductile iron flanges.

DESIGN

- 4.1 The valve body shall be full flow equal to nominal pipe diameter area at all points through the valve and shall be equipped with a threaded adjustable open stop. The body seat shall be O-ring sealed and field replaceable without removing the valve from the line.
- 4.2 The top access port shall be full size, allowing removal of the disc without removing the valve from the line. The access cover shall be domed in shape to provide flushing action over the disc for operating in lines containing high solids content.
- 4.3 The disc shall be of one-piece construction and connected to the shaft with a disc arm and two pivot pins to provide pivot action to allow self-adjusting seating at all pressures. Discs shall be convex shape for lift, stabilization and strength.
- 4.4 When side oil cushions are specified, the shaft and keys shall be sized to withstand the full differential pressure torque.
- 4.5 When specified, metal seated valves shall have aluminum bronze seats.
- 4.6 When specified, resilient seated valves shall have a disc seat of a resilient material with integral O-ring type sealing surface for drop tight shut-off at high and low pressures and for easy replacement in the field without removing the valve from the line.
- 4.7 The shaft seals shall be a replaceable lead free bronze O-ring cartridge type.
- 4.8 Valves shall be factory equipped with a lever and weight assembly. The lever shall be equipped with three holes for adjusting the bolted weight assembly. The 8 in. oil cushion valves shall have one weight and lever assembly; 14 in. and larger valves shall be factory equipped with two lever and weight assemblies. When the valve is closed, the

lever and weight shall be located 30 degrees below horizontal.

- 4.9 A bottom oil cushion shall be factory installed to provide hydraulic control of the final 10% of valve closure and reduce water hammer normally associated with rapid flow reversal conditions on pump shut down. The cushion shall consist of a high pressure hydraulic cylinder, adjustable external flow control valve, pressurized oil reservoir and piping designed to control the closing speed of the last 10% of travel in 1-5 seconds. A cushion spacer which connects the cylinder to the valve shall have an air gap to prevent hydraulic fluid from entering the valve and contaminating the water system. A snubber rod fitted with O-ring seals and rod wiper scrapers shall make contact with the lower portion of the disc during closure.
- 4.10 When specified on side oil cushion valves as 2-stage oil cushion, the control function is as follows: During closure, the oil cylinder controls the speed of closure. As the check valve closes, oil from the bottom port of the cylinder is controlled by the Flow Control valve, typically 5-30 seconds. During the last 10% of travel, the closure is controlled using the internal cushion adjustment, typically 1-3 seconds.
- 4.11 When specified on side oil cushion valves as 3-stage oil cushion, the control function is as follows: During closure, the oil cylinder controls the speed of closure in three stages. As the check valve closes, oil from the bottom port of the cylinder flows freely through the 2-way valve allowing the valve to close rapidly, typically 1 to 2 seconds. When the valve travels to the 50% closed position (adjustable), the 2-way valve closes. The oil now is controlled by the Flow Control Valve, typically 5-30 seconds. During the last 10% of travel, the closure is controlled using the internal cushion adjustment, typically 1-3 seconds.

MATERIALS

- 5.1 The valve body, cover and disc shall be constructed of ASTM A536 Grade 65-45-12 ductile iron.
- 5.2 The shaft shall be ASTM A276, T304 stainless steel for bottom oil cushion valves and ASTM A564 T630 H900 alloy stainless steel for side oil cushion valves.
- 5.3 The exterior and interior of the valve shall be coated with an NSF/ANSI 61 approved fusion bonded epoxy coating.
- 5.4 The removable body seat and integral metal disc seat shall be constructed of aluminum bronze C95400.
- 5.5 The optional resilient seated disc seat shall be precision molded Buna-N (NBR), ASTM D2000-BG. When specified, optional seat material includes EPDM.
- 5.6 The disc arm and external levers shall be ASTM A536 Grade 65-45-12 ductile iron.

MANUFACTURE

- 6.1 Manufacturer shall demonstrate a minimum of five (5) years' experience in the manufacture of swing check valves.
- 6.2 All valves shall be hydrostatically and seat tested per AWWA C508 to demonstrate zero leakage and structural integrity. When requested, the manufacturer shall provide test certificates, dimensional drawings, parts list drawings, and operation and maintenance manuals.
- 6.3 Swing Check Valves shall be Series 7900B and 7900S as manufactured by Val-Matic® Valve & Mfg. Corporation, Elmhurst, IL USA or approved equal.



Val-Matic's quality of design and meticulous workmanship has set the standards by which all others are measured. Quality design features such as the AWWA **Ener-G® Ball Valve** with its energy efficient design, fusion bonded epoxy and adjustable resilient seating....**Cam-Centric® Plug Valves** have more requested features than any other eccentric plug valve....**American-BFV® Butterfly Valves** include a field replaceable seat without the need for special tools....**Tilted Disc® Check Valves** with high strength and wear resistant aluminum bronze trim as standard....**Silent Check Valves** featuring combined resilient/metal-to-metal seating and are **NSF/ANSI 61 & 372 Certified**....**Sure Seal Foot Valves** provided with a heavy duty stainless steel screened inlet....**Swing-Flex® and Surgebuster® Check Valves** designed with an unrestricted full flow area....**Swing Check Valves** with field

adjustable closure versatility....**Dual Disc® Check Valves** utilizing stabilized components to provide extended life....**Air Release, Air/Vacuum and Combination Air Valves** provided standard with Type 316 stainless steel trim....**VaultSafe®** family of products includes the **FloodSafe® Inflow Preventer, FrostSafe®** two-way damper and the **VentSafe®** vent pipe security cage. The **QuadroSphere® Trunnion Ball Valve** features a unique ball design with recessed surfaces creating additional flow paths to provide a self-cleaning action and reduced wear and torque.

Val-Matic is totally committed to providing the highest quality valves and outstanding service to our customers. Complete customer satisfaction is our goal. **Make the change to quality, specify Val-Matic!**



Val-Matic Valve and Manufacturing Corp.
 905 Riverside Drive, Elmhurst, IL 60126
 Phone: 630-941-7600 • Fax: 630-941-8042
 www.valmatic.com • valves@valmatic.com