

VALMATIC®

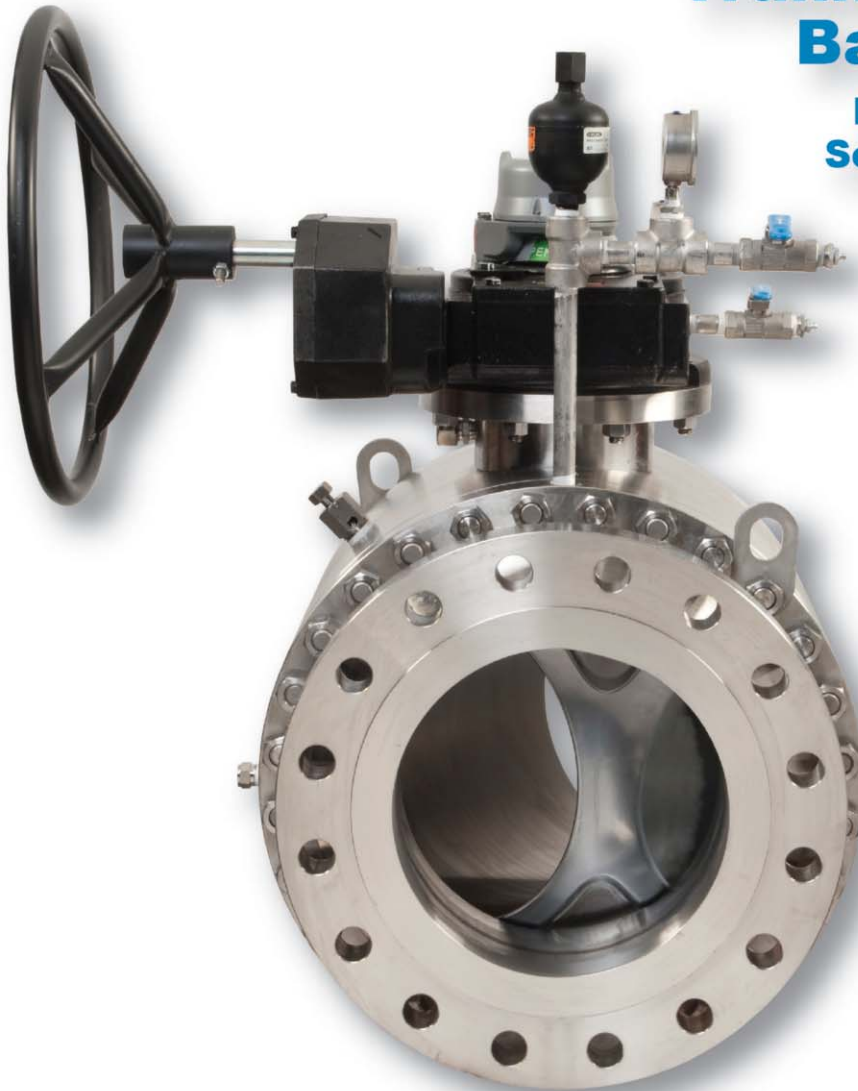

QuadroSphere® Trunnion Mounted Ball Valves

Ring Master®
Seating System



www.valmatic.com

API 6D Certified
API 607 Certified

Feature Highlights

The QuadroSphere® Ball Valve has over 20 years of proven performance in numerous applications in the power, oil & gas, refinery, mining, steel, chemical, geothermal and petrochemical industries.

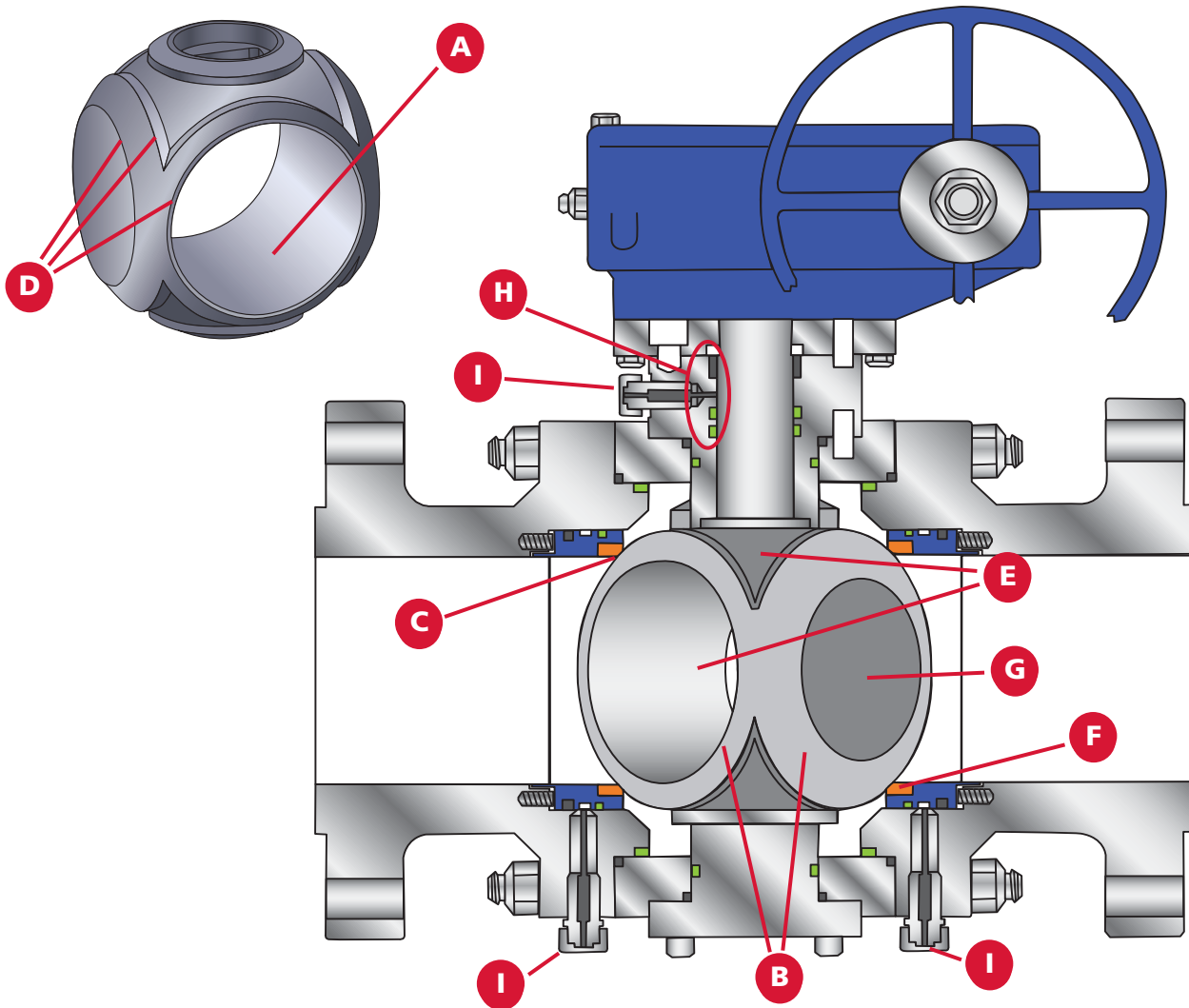

Exclusive QuadroSphere® Advantages

A. QuadroSphere® Ball

Unique contoured full port ball adds 4 additional flow paths: over, under and around the sides for self-flushing the ball cavity.

B. Wear Resistance

Reduced ball to seat contact creating up to 70% less wear.

C. Low Torque

Minimal ball to seat contact when opening or closing lowers the running torque.

D. Self-Cleaning Action

Four recessed surfaces on the ball provide lipped edges for scraping the seats clean to avoid the buildup of solids and scale.

E. Multiple Flow Paths

Reduces cavitation and minimizes velocity spikes, reducing wear and erosion.

F. Protected Seating

Seat surfaces are out of the flow path and fully protected from direct flow.

G. Hardened Ball

Ground and polished hard chrome plated stainless steel ball provides low operating friction and abrasion resistance.

H. Stem Seals

Double O-ring stem seals are backed up by graphite packing compression rings as standard.

I. Injection Fittings

In the event of damage to the seat insert or stem seals, sealant can be injected to temporarily seal the valve until repairs can be made.

Features & Benefits

QuadroSphere® Ball

The QuadroSphere® Ball is not a typical ball design. Surfaces of the full port ball that are non-essential to sealing have been recessed in all 4 quadrants. The surfaces of the ball that have been recessed create additional flow paths allowing the flow and particulates to move freely above, below and around the sides of the ball when moving from closed to open position. Seat ring contact to the ball has minimal contact area, which reduces wear and operating torques, due to less friction. The recessed surfaces on the ball also provide lipped edges that wipe the seat surfaces clean during opening and closing to avoid particulate buildup. The ball has two sets of seating surfaces to provide shut off in the fully closed position and protect the seats in the fully open position.

Self-Cleaning Features

Typical ball valves allow liquids and solids to be trapped within the body/ball cavity, resulting in solids accumulating around the ball that can cause clogging and/or damage to the seating surfaces. When the QuadroSphere® Ball cycles, its unique 4 recessed surfaces allow solids to be flushed from the body/ball cavity to prevent buildup of the solids around the back of the seat rings and bearings, Figure 1.

Protected Seating Surfaces

The QuadroSphere® Ball protects its seats from media velocity by minimizing contact of the upstream seating surfaces during cycles. When the QuadroSphere® Ball closes, the media applies pressure to the upstream seat ring pushing it against the ball's upstream sealing surface for leak tight performance.

Lower Torque Requirements

The contour machining of the ball substantially reduces the ball to seat surface contact. This creates less resistance during cycles, lowering the torque to operate the QuadroSphere® Ball Valve.

Anti-Blowout Stem

The stem has an integral collar to prevent the stem from being ejected from the valve, while under line pressure per API 6D and ASME B16.34 standards.

Stem Seals & Bearings

The area around the stem seals and bearings is flushed clean each time the valve cycles from open to close. This helps to eliminate solids build up, that can damage the seals and bearings during operation, Figure 1.

Body & Ball Construction

The QuadroSphere® body and ball are forgings to provide superior surface finish and structural integrity. Forgings prevent defects, normally associated with castings such as pitting, sand inclusions, porosity and any need for weld repairs.

70% Less Wear

Unlike typical ball valves the QuadroSphere® Ball maintains a fraction of the resistance across the seating surfaces when cycling, reducing wear up to 70% and improving the performance life of the ball and seats. As the ball cycles, 4 additional flow paths (over, under and around both sides) are created by the recessed surfaces, eliminating localized, high velocity impingement upon the downstream seat as with typical ball valves.

Industry Compliance

The QuadroSphere® Ball Valve has undergone tests to demonstrate its unique abrasion resistant ball design in severe applications. With over 20 years of proven performance, the QuadroSphere® Ball Valve solves the most difficult application problems in many industries. The QuadroSphere® Ball Valve is designed in accordance with API 6D and ASME B16.34 requirements. The valve carries the API 6D Monogram and has been certified to API 607, Fire Test standard. The QuadroSphere® meets standards: API, ASME/ANSI, BS, ISO, MSS and NACE.

QuadroSphere® allows debris to be flushed from the valve body.

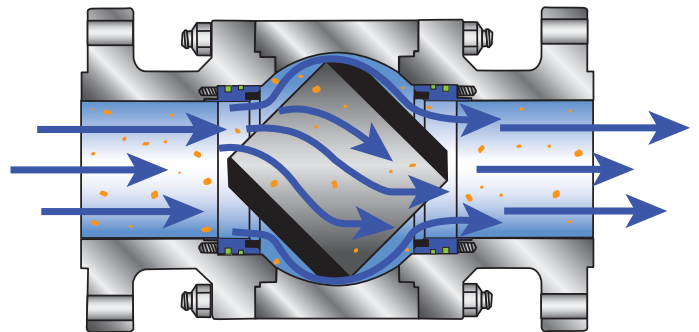

Typical Ball Valve allows debris and solids to accumulate.

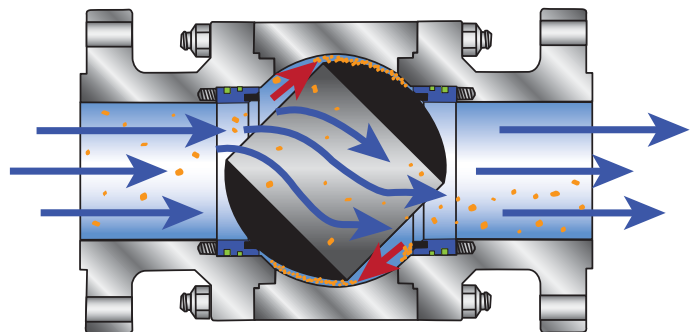
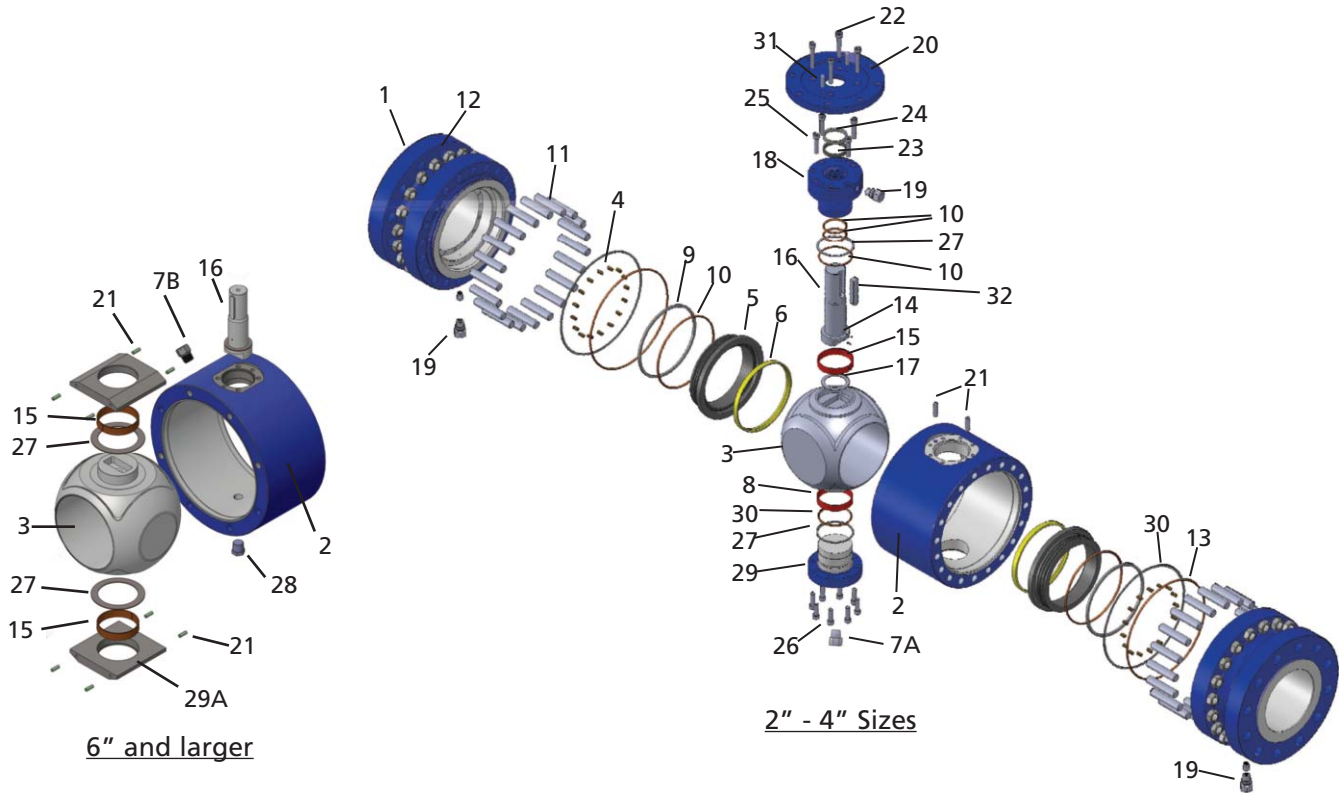

Figure 1. Flow Pattern Comparison

Construction



Assy No.	Component	Standard Quadrosphere® Carbon Steel	Standard Quadrosphere® Stainless Steel	Assy No.	Component	Standard Quadrosphere® Carbon Steel	Standard Quadrosphere® Stainless Steel
1	Body Flange	ASTM A105 CS	ASTM A182 Type 316SS	17	Stem Bearing	RPTFE	RPTFE
2	Body	ASTM A105 CS	ASTM A182 Type 316SS	18	Stem Cover	ASTM A105 CS	ASTM A182 Type 316SS
3	QS Ball	ASTM A182 Type 316SS Hard Chrome Plating	ASTM A182 Type 316SS Hard Chrome Plating	19	Injection Fitting	ASTM A105 CS	ASTM A276 Type 316SS
4	Spring	Inconel X-750	Inconel X-750	20	Adaptor/Packing Retainer	ASTM A105 CS	ASTM A182 Type 316SS
5	Seat Ring	ASTM A182 Type 316SS	ASTM A182 Type 316SS	21	Pin	Carbon Steel	ASTM A276 Type 316SS
6	Seat Insert	RPTFE (150-300) PEEK (600-2500)	RPTFE (150-300) PEEK (600-2500)	22	Screw	ASTM A193-B7M	ASTM A193-B8M
7A	Vent Valve	AISI 316SS	AISI 316SS	23	Packing	Flex Graphite	Flex Graphite
7B	Relief Valve	AISI 316SS	AISI 316SS	24	Gland	ASTM A182 Type 316SS	ASTM A182 Type 316SS
8	Bearing	1045 + PTFE	1045 + PTFE	25	Screw	ASTM A193-B7M	ASTM A193-B8M
9	Seat Gasket	Graphite	Graphite	26	Screw	ASTM A193-B7M	ASTM A193-B8M
10	Seat & Stem O-rings	Viton®	Viton®	27	Gasket	316 + Graphite	316 + Graphite
11	Body Stud	ASTM A193-B7M	ASTM A193-B8M	28	Drain Plug	AISI 316SS	AISI 316SS
12	Body Nut	ASTM A194-2HM	ASTM A194-8M	29	Post Trunnion	ASTM A105 CS	ASTM A182 Type 316SS
13	Body Gasket	316SS + Graphite	316SS + Graphite	29A	Plate Trunnion	4130/4140 + ENP	A182 GR 316
14	Antistatic	ASTM A276 Type 316SS	ASTM A276 Type 316SS	30	O-ring	Viton®	Viton®
15	Bearing	1045 + PTFE	1045 + PTFE	31	Pin	Carbon Steel	ASTM A276 Type 316SS
16	Stem	ASTM A182 Type 316SS	ASTM A182 Type 316SS	32	Key Pin	1045 Carbon Steel	ASTM A479 Type 304SS / 420SS

Component Limits

Component Pressure & Temperature Limits

Component Designation Legend

Seat Insert Material: RPTFE, PEEK, Nylon, Devlon®, Carbon Fiber Filled PEEK (CFFP), Metal

O-Ring Material: Aflas®, HNBR, Chemraz®, Markez®, Kalrez®, Viton®, Viton® AED, FF200, Graphite

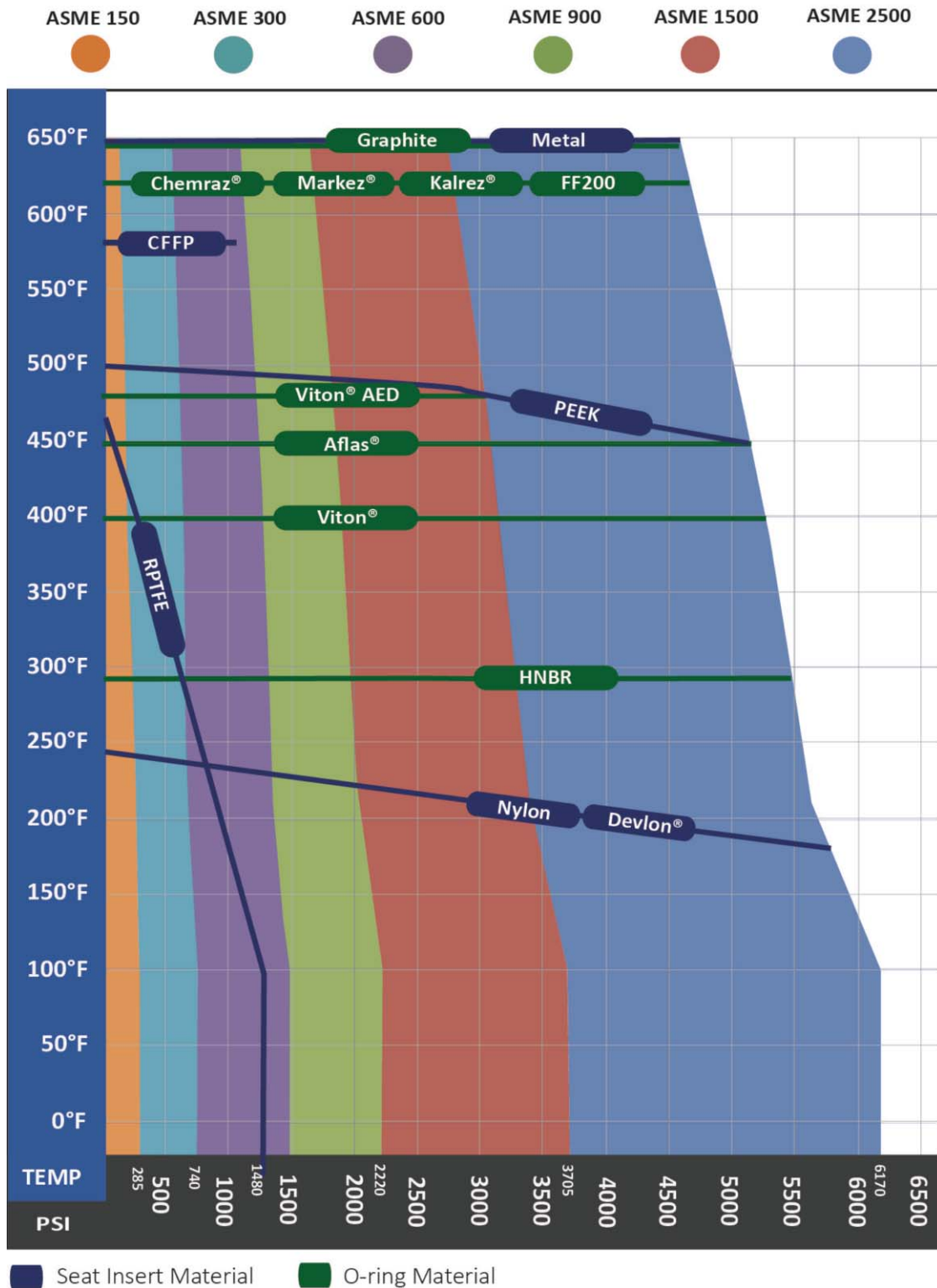

Figure 2 - Pressure and Temperature Limits

Design Features

Ball Valve Single Piston Effect Seating

Single Piston Effect Seating (API 6D DBB)

In the standard configuration, the ball valve seats are floating and are activated by springs and line pressure to seal tightly against the QuadroSphere® Ball. The seats have an O-ring seal on the outside diameter and a resilient seat insert at the center creating a piston effect area. Upstream and downstream line pressure act over this piston area to force the seals with the required thrust to seal tightly against the ball, Figure 3.

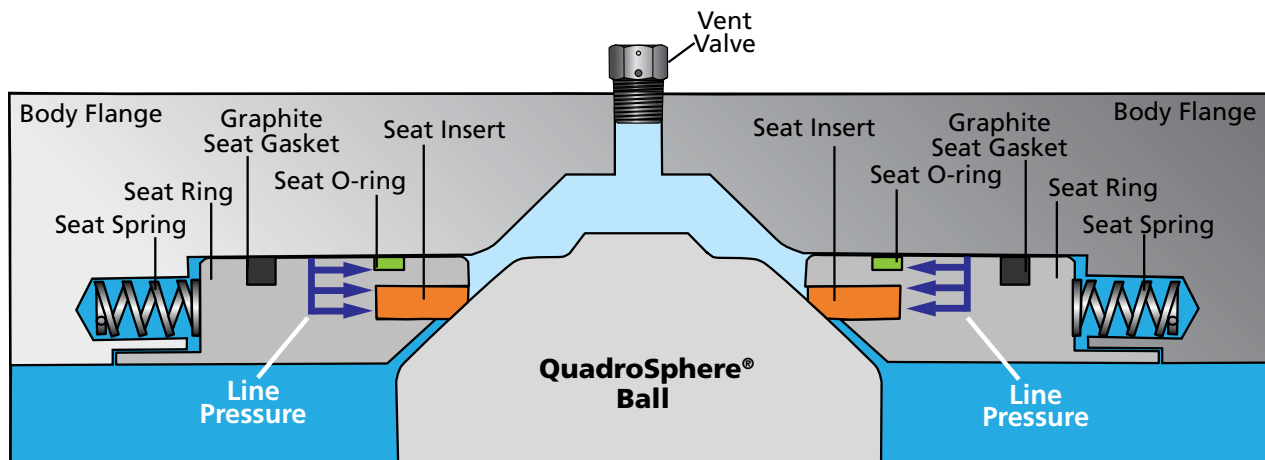

Figure 3 - Bi-directional Sealing

If pressure in the valve cavity between the seats exceeds the upstream or downstream pressure, the piston effect will work in the opposite direction and automatically relieve any overpressure, Figure 4. Additionally, the valve body is equipped with vent and drain connections to verify seat integrity with the valve in service. The single piston effect is defined in API 6D as Double-Block-and-Bleed (DBB) design. Since the cavity is automatically relieved, any leakage through the first seat will also be relieved by the second seat so DBB valves do not provide positive double isolation.

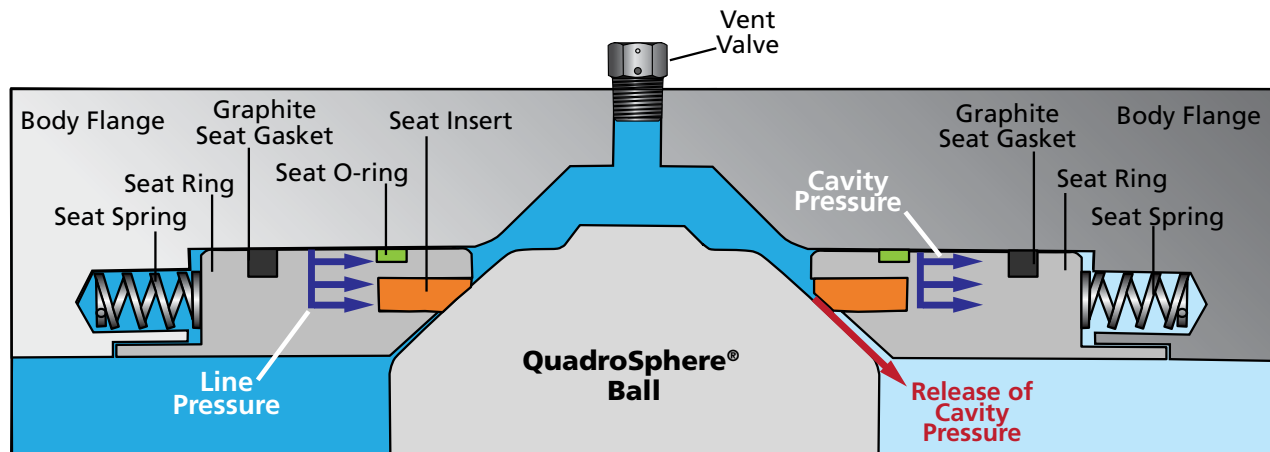

Figure 4 - Self-Relieving Seats

Ball Valve Double Piston Effect Seating

Double Piston Effect Seating (API 6D DIB)

In the optional configuration, the ball valve seats have an enlarged O-ring groove that allows the O-ring to be activated bi-directionally by either the line pressure or the cavity pressure. As with the single piston design, the line pressure acts over the piston area to force the seals with the required thrust to seal tightly against the QuadroSphere® Ball, Figure 5.

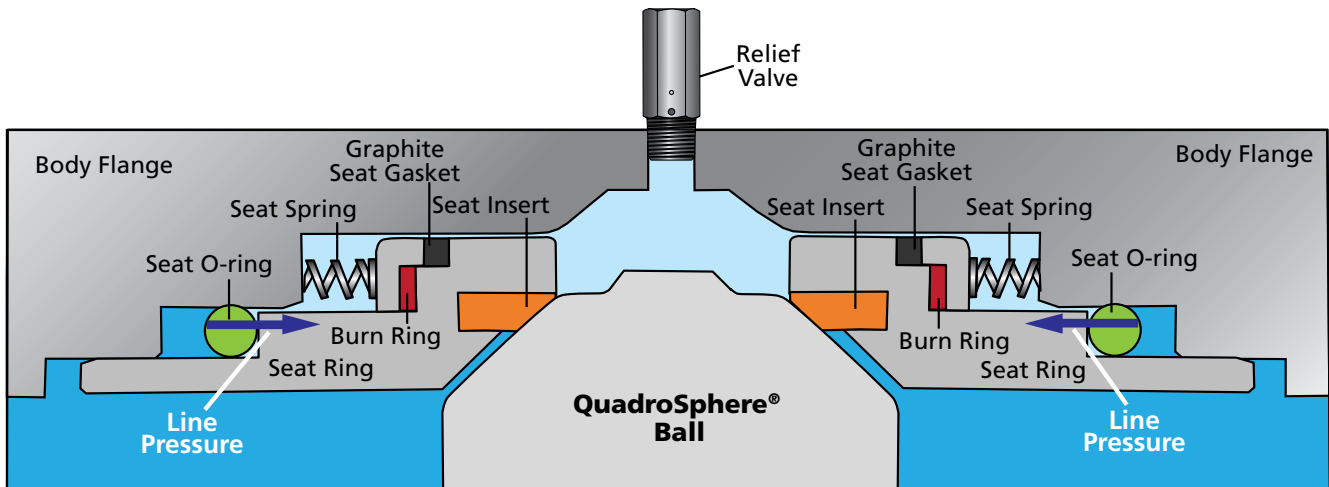

Figure 5 - Cavity Isolation

In addition, the cavity pressure is connected to the opposite O-ring seal and will also force the ball valve seat against the ball, Figure 6. Therefore, both valve seats will seal with line pressure from the same direction when needed, providing positive double isolation. To avoid overpressure in the ball valve cavity due to thermal expansion, an automatic cavity pressure relief device is provided. The double piston effect is defined in API 6D as Double-Isolation-and-Bleed (DIB) and can be provided in one or both directions. Since both the upstream and downstream seats are activated by line and cavity pressure, DIB valves provide reliable double isolation.

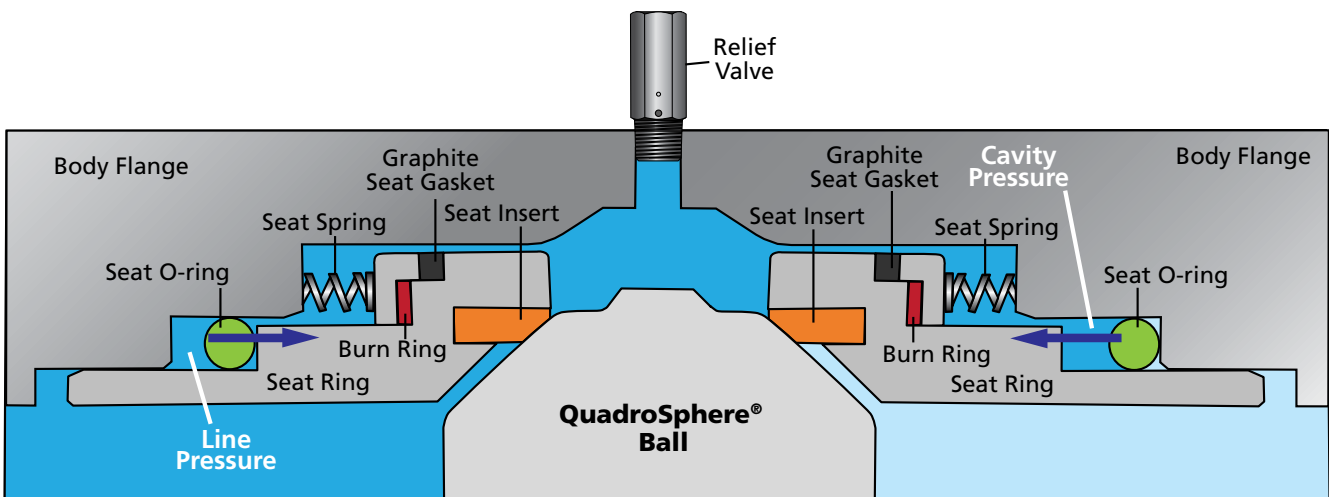

Figure 6 - Double Isolation of Cavity

Design Features

Soft Seated Valves

QuadroSphere® Ball Valves are equipped with two independent floating seat rings. These seat rings have resilient seat inserts installed into the seat ring to provide primary soft seating in addition to the secondary metal to metal seating between the ball and the seat ring. The sealing between the seat ring and the valve body flange is achieved by means of the seat O-ring and graphite seat gasket, Figure 7.

Bi-Directional Seating

The standard QuadroSphere® Ball Valve has bi-directional seating, which means the valve will seal with the line pressure coming from the upstream side of the valve or from the downstream side of the valve. Also the valve can be installed in the pipeline without having to ensure proper seating orientation of the valve, unlike some other ball valves.

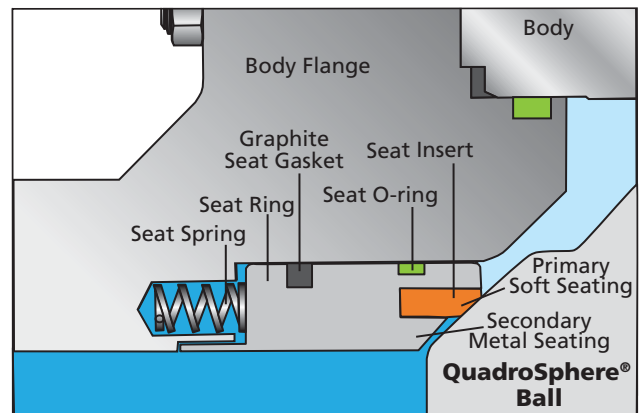

Figure 7 - Soft Seated Valves

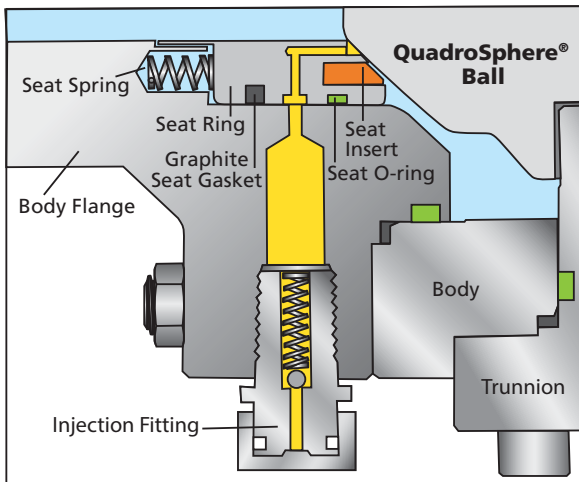

Figure 8 - Emergency Sealant Injection

Fire-Safe - Single Piston

The Fire-Safe QuadroSphere® Ball Valve is designed, tested and certified to API 607. Figure 9 shows the single piston standard seat design. During a fire the seat insert and O-ring are destroyed and the seat gasket, made of graphite material, will remain to seal off the media along with the secondary metal seat on the seat ring.

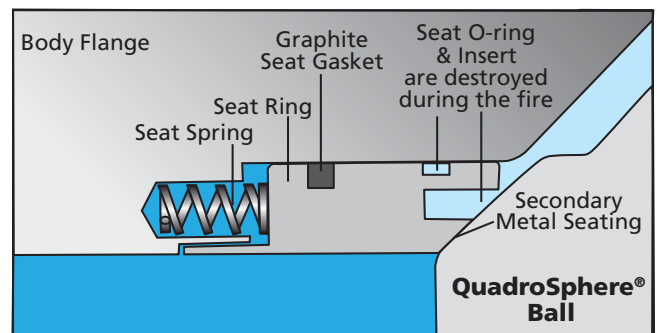

Figure 9 - Fire-Safe Single Piston

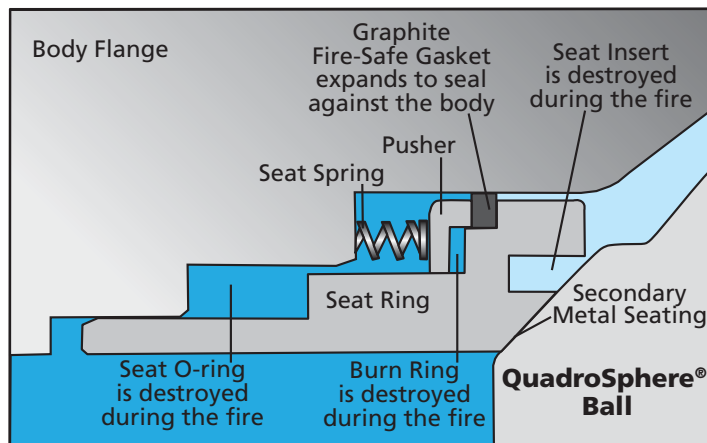

Figure 10 - Fire Safe - Double Piston

Emergency Sealant Injection

The design of QuadroSphere® Ball Valves does not require the use of a sealant injection for standard operation. An emergency sealant injection system for stem seals and seat rings is a standard feature on all 6 NPS and larger QuadroSphere® Ball Valves with the single piston design. In the event of damage to the seat insert or stem seals, sealant can be injected to temporarily seal the valve until repairs can be made, Figure 8.

(For certain chemical applications, the sealant injection fittings may not be suitable. Consult factory with application for compatibility.)

Fire-Safe - Double Piston

Figure 10 shows the seat configuration before the fire, where there is a gap between the gasket and the body. Figure 10 shows the seat configuration after a fire, where the burn ring has melted away and permits the seat graphite pusher to compress the gasket against the body to create a seal. The Double Piston Fire-Safe design does not permit the use of the emergency sealant injection.

Industry	Applications
Oil & Gas Pipelines	Tank Farms, Meter Stations, Pumps Isolation, Offshore Platforms, Fracking Water Treatment Systems, Heat Exchanger Water, Compressor Stations, Pig Launchers & Receivers, SAGD
Salt Domes	Salt Dome Brine & Gas, Salt Dome Wells & Storage
Refining	Drum Feed, Drum Blow Down, Vapor Lines, Quench Water, Bypass, Drain, Low Pressure Steam, Hot Oil, Isolation
Geothermal	Concentrated Brine & Natural Gas, Well Christmas Tree Master & Crown Valve, Vent Lines
Power	Fly Ash Water/Slurry, River Water, Pump Isolation, Crude Oil, Low Steam Pressure
Chemical	PVC Reactors Outlet/Diverter Service, PVC Waste Pump Isolation, PVC Slurry, Lock Hopper Isolation, Reactor Feed & Isolation
Pulp & Paper	White, Green and Black Liquor
Petrochemical	LNG Vaporization
Mining/Steel	Tailings, Dirty Mine Water, Gases & Liquids
Wastewater	Sludge, Treatment Chemicals, Waste Oil, Leachate

Installations



Master Valve Geothermal Brine



Salt Cavern Brine Well



Crude Oil Pumping Station Pig Launcher/Receiver



Salt Dome Brine & Gas Pumping Station

Ring Master®

The Ring Master® Seating System shown in Figure 12 provides excellent shut-off and ease of operation in applications when sand, scale, powders and other solids are present in the media. The Ring Master® is composed of a seat retaining ring and a dynamic, pressure-energized seat insert composed of various materials such as RTFE, PEEK, or Metal. The seat is energized with a clean independent external pressure source. Because the pressure behind the dynamic seat is higher than the line pressure, there will be no ingress of media from the pipeline into the seat cavity, ensuring the free axial movement of the seat against the ball under all process conditions.



Figure 11 - QuadroSphere® with Ring Master® Seating System

Figure 11 is a QuadroSphere® Ball Valve equipped with a Ring Master® Seating System, which provides bi-directional shut-off and positive double isolation and bleed service (DIB). It will handle flow from either side and does not have to be installed in a preferred direction. The two seats operate independently of each other and therefore provide reliable double isolation. To avoid overpressure in the ball valve cavity due to thermal expansion, an automatic cavity pressure relief device is provided.

The ball valve seat inserts are activated by wave springs and external pressure to seal tightly against the ball. The external pressure is applied to the seat by a process compatible fluid or gas such as grease, air, nitrogen, or other clean fluid. The body is configured with the appropriate connections, piping, and valves to facilitate the application of the external pressure. The pressure is provided and maintained by either a pre-charged accumulator, an external regulated pressure source, or other clean fluid.

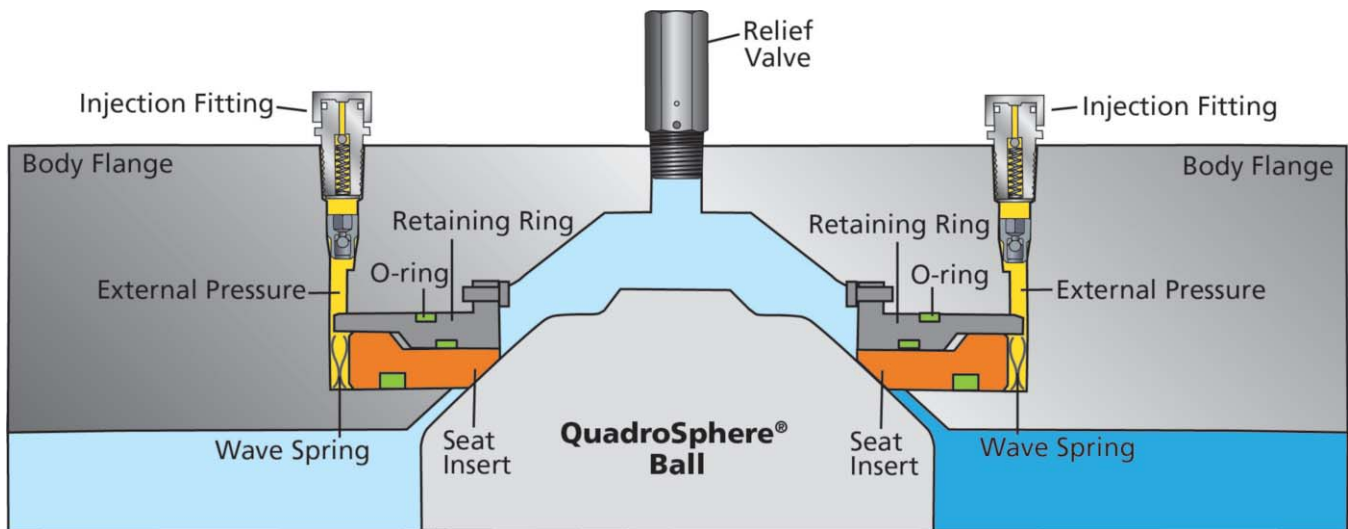

Figure 12 - Ring Master® Seating System

External Sealing Options

Spring Force

The Ring Master® floating seats are activated by wave springs and external pressure to seal tight against the QuadroSphere® Ball. For higher pressures, the external injection fitting can be used to inject sealant into the spring cavity behind the seat insert and provide additional seating force when needed or act as an emergency backup when needed. An internal check valve is provided to allow the removal of the injection fitting so that an external pressure source can also be used.

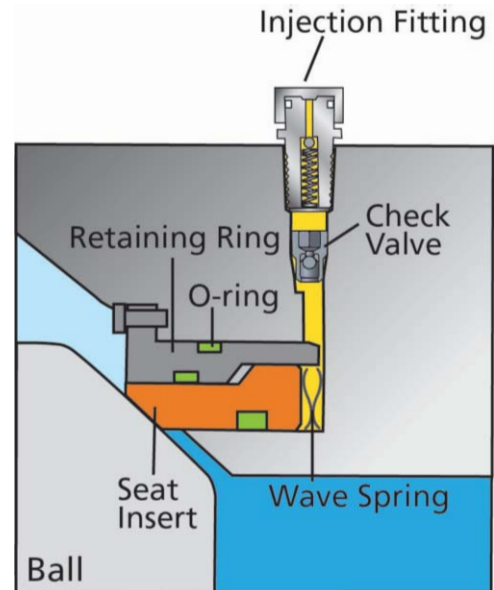

Figure 13 - Spring Force Sealing Option

External Pressure

The use of external pressure such as air, nitrogen, grease, or other clean fluid can be used to power the seat insert. The external pressure should be at least equal to the expected process pressure. The fluid can be filtered and regulated as shown in Figure 14.

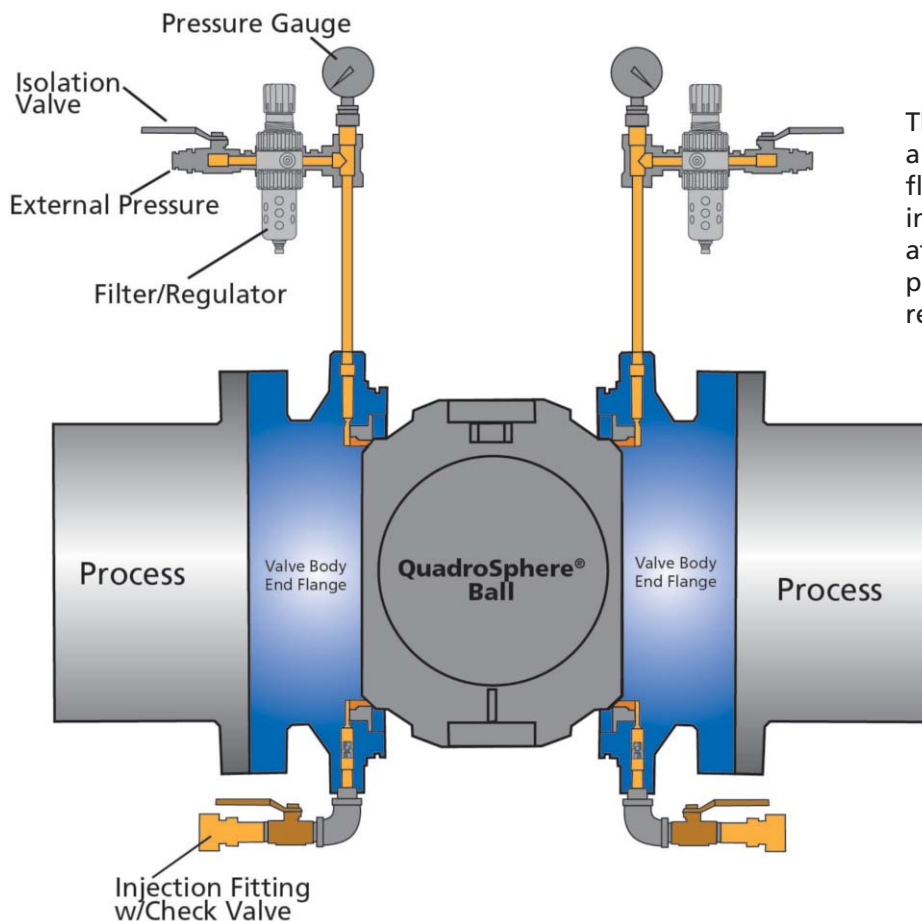
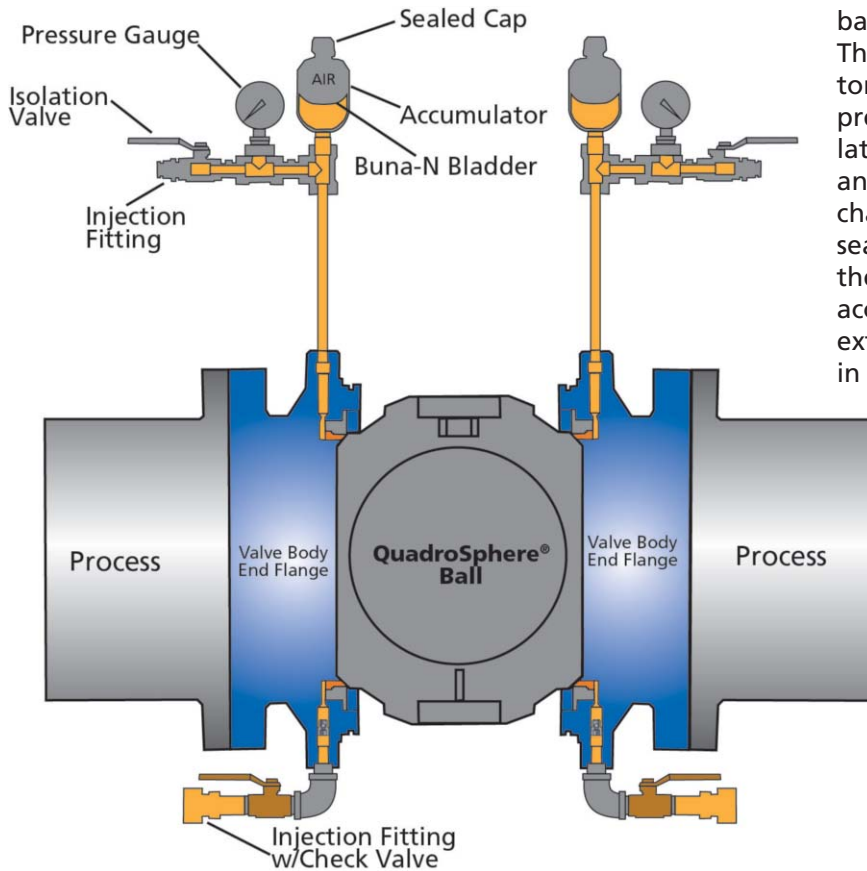

Figure 14 - External Pressure Sealing Option

External Sealing Options

Accumulator & Pressurized Fluid



When the process fluid contains solids, an independent sealant or other fluid compatible with the process media is used to pressurize the seat insert to force it against the ball and provide tight shutoff, Figure 15. The pressurized fluid is injected in the bottom port until the seat cavity is filled and pressurized fluid is expelled out of the isolation valve. The isolation valve is closed and the injection is continued until the pre-charged accumulator is filled to the desired sealing pressure, which should be above the maximum system line pressure. The accumulator will maintain that pressure for extended periods independent of changes in the process conditions.

Figure 15 - Accumulator & Pressurized Fluid Option

Installations



QuadroSphere® with Ring Master® Seating System for Geothermal Brine Clarifier Tank Valve



QuadroSphere® with Injection Fitting to be used in Lock Hopper Service for a Pyrolysis Reactor

Product Scope

QuadroSphere® and Ring Master®

Series	ASME Rating	Size Range NPS (DN)	CWP* (psig)
4700A1	150	2 - 24 (50-600)	285
4700A3	300	2 - 24 (50-600)	740
4700A6	600	2 - 24 (50-600)	1480
4700A9	900	2 - 16 (50-400)	2220
4700AA	1500	2 - 16 (50-400)	3705
4700AB	2500	2 - 6 (50-150)	6170

*Based on Carbon Steel

Consult factory for additional sizes and pressure class availability.

Industry Compliance

Basic Design	ASME B16.34/API 6D
Face-to-Face Dimension	API 6D
Flanged End Dimension	ASME B16.5
Inspected & Tested to	API 6D
Firesafe Certification	API 607
Quality Certification	ISO 9001
Fugitive Emission	ISO-15848-2
Actuator Mounting	ISO 5211

Product Options:

Extended bonnet, Double piston effect seats w/ relief valve, Special coatings, NACE
Low pressure seat tests can be performed per customer requirements.

End Connections:

Standard: Flanged

Optional: Butt Weld or Ring Tongue Joint (RTJ)

ASME Ratings

Pressure/Temperature Ratings (PSIG)

Material		Class 150	Class 300	Class 600	Class 900	Class 1500	Class 2500
A105 & LF2	100°F	285	740	1480	2220	3705	6170
	200°F	260	680	1360	2035	3395	5655
	300°F	230	655	1310	1965	3270	5450
	400°F	200	635	1265	1900	3170	5280
	500°F	170	605	1205	1810	3015	5025
	600°F	140	570	1135	1705	2840	4730
F316	100°F	275	720	1440	2160	3600	6000
	200°F	235	620	1240	1860	3095	5160
	300°F	215	560	1120	1680	2795	4660
	400°F	195	515	1025	1540	2570	4280
	500°F	170	480	955	1435	2390	3980
	600°F	140	450	900	1355	2255	3760

Consult factory for higher temperatures.

Available Materials

Component	Material
Body	LF2, LCB, Duplex Stainless Steel
Seat Insert	RPTFE, PEEK, Nylon, Devlon®, Carbon Fiber Filled PEEK (CFFP), Metal
Seat Ring	Stainless Steel, CS/ENP, LF2/ENP, SS410
Seal	Aflas®, Chemraz®, Markez®, Viton® AED, Viton, HNBR, Kalrez®, FF200, Graphite
Stem	17-4PH, Duplex Stainless Steel, Stainless Steel, CS/Plated
Ball Surface	Stellite, Electroless Nickel Plating, Tungsten Carbide Coating
Metal Seat	Seat Ring Faced with Stellite, Electroless Nickel Plating, Tungsten Carbide Coating over various seat ring materials

Note: Consult Factory for other materials.

Material	Temperature	
	Low	High
Aflas®	-5°F	450°F
CFFP	20°F	580°F
Chemraz®	-4°F	615°F
Devlon®	-40°F	250°F
FF200	5°F	615°F
HNBR	-40°F	290°F
Kalrez®	0°F	615°F
Markez®	5°F	615°F
Nylon	-40°F	250°F
PEEK	20°F	500°F
RPTFE	-50°F	450°F
Viton	-15°F	400°F
Viton® AED	-5°F	475°F

Flow Coefficients (Cv)

Size (NPS)	ASME 150	ASME 300	ASME 600	ASME 900	ASME 1500	ASME 2500	Size (DN)
2	450	430	370	330	320	300	50
3	1360	1100	1020	920	830	520	80
4	2000	2000	1850	1760	1660	1200	100
6	5500	5500	4400	4300	4167	2900	150
8	10000	10000	8450	8400	8013		200
10	17000	17000	14250	14160	13309		250
12	24000	24000	24000	21320	17073		300
14	32600	28000	28000	26600	24500		350
16	44700	36000	36000	36000	33215		400
18	57825	56225	57410				450
20	74775	71800	65463				500
24	113284	109414	98963			600	

Dimensions

Trunnion Design • 2 thru 24 NPS ASME Class 150

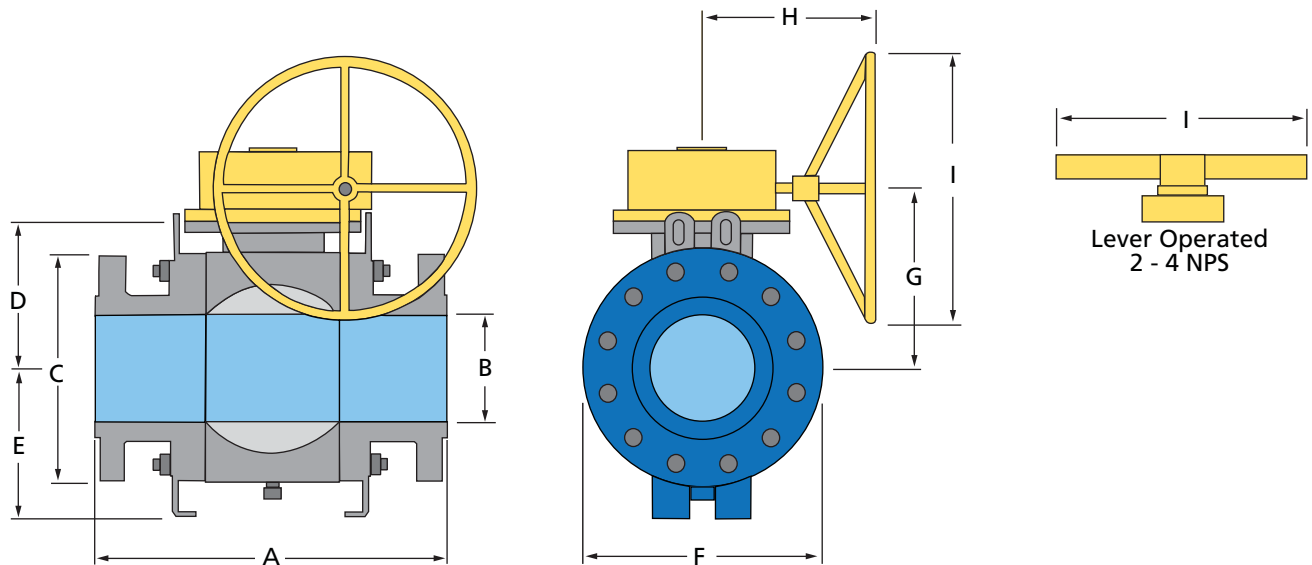

Class 150 - Dimensions in Inches (mm)										
Size NPS (DN)	A	B	C	D	E	F	G	H	I	Weight LB (KG)
2 (50)	7.00 (178)	1.93 (49)	6.00 (152.4)	3.88 (98.43)	-	6.02 (153)	6.40 (163)	-	11.80 (300)	56 (25)
3 (80)	8.00 (203)	2.91 (74)	7.50 (191)	5.38 (136.3)	-	7.52 (191)	6.40 (163)	-	18.10 (460)	76 (35)
4 (100)	9.00 (229)	3.94 (100)	9.00 (228.6)	6.19 (157.2)	-	9.13 (232)	7.10 (180)	-	18.10 (460)	115 (52)
6 (150)	15.50 (394)	5.91 (150)	11.00 (279.4)	7.00 (177.8)	7.36 (187)	12.09 (307)	10.90 (277)	11.94 (303.2)	15.70 (400)	415 (189)
8 (200)	18.00 (457)	7.91 (201)	13.50 (342.9)	8.75 (222.3)	8.82 (224)	15.43 (392)	14.10 (358)	11.94 (303.2)	15.70 (400)	752 (342)
10 (250)	21.00 (533)	9.92 (252)	16.00 (406.4)	11.25 (285.8)	10.94 (278)	18.31 (465)	16.20 (412)	14.63 (371.5)	19.70 (600)	1020 (464)
12 (300)	24.00 (610)	11.93 (303)	19.00 (482.6)	12.63 (320.7)	12.05 (306)	21.38 (543)	18.20 (462)	14.63 (371.5)	23.60 (600)	1555 (707)
14 (350)	27.00 (686)	13.15 (334)	21.00 (533.4)	15.70 (400)	15.30 (388)	25.10 (638)	18.50 (470)	20.40 (518)	23.60 (600)	1600 (727)
16 (400)	30.00 (762)	15.16 (385)	23.50 (596.9)	16.70 (423)	17.70 (450)	28.00 (710)	19.40 (493)	18.70 (475)	27.60 (700)	2244 (1020)
18 (450)	34.00 (864)	17.17 (436)	25.00 (635)	19.10 (485)	19.50 (495)	31.90 (810)	22.30 (566)	22.60 (575)	27.60 (700)	2673 (1215)
20 (500)	36.00 (914)	19.17 (487)	27.50 (698.5)	21.10 (537)	21.40 (543)	34.10 (865)	24.30 (618)	22.60 (575)	27.60 (700)	3945 (1793)
24 (600)	42.00 (1067)	21.18 (589)	32.00 (813)	24.30 (616)	23.20 (590.5)	40.40 (1025)	27.80 (705)	23.30 (592)	31.50 (800)	6818 (3099)

- Notes:
1. Ball Diameter Dimensions (B) are per API 6D design convention for full port valves.
 2. Additional materials and design configurations available. Please contact factory.

Dimensions

Trunnion Design • 2 thru 24 NPS • ASME Class 300

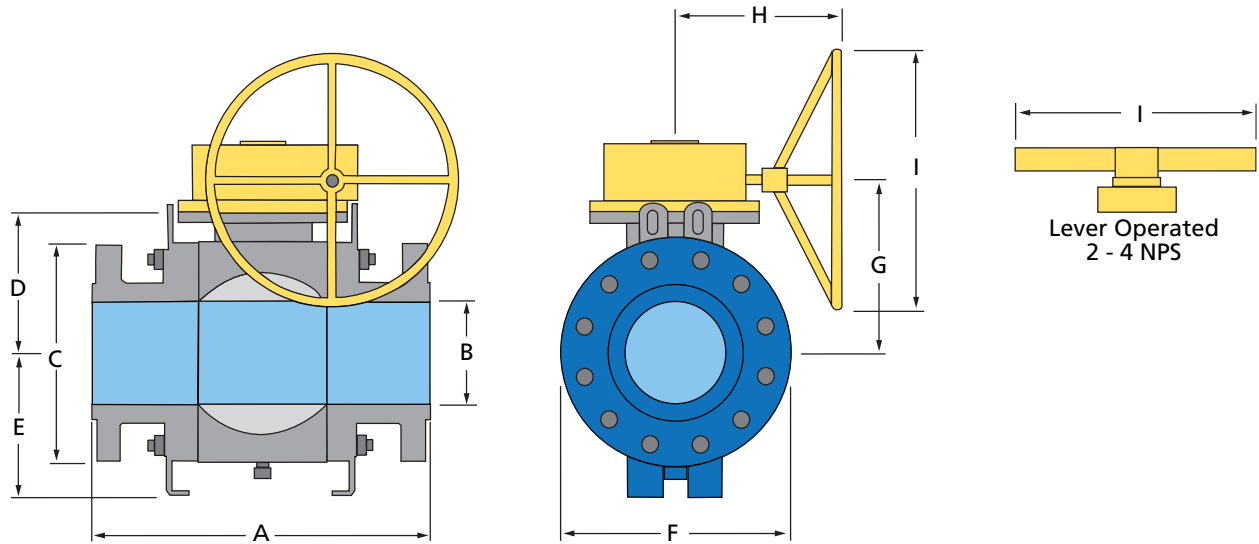

Class 300 - Dimensions in Inches (mm)

Size NPS (DN)	A	B	C	D	E	F	G	H	I	Weight LB (KG)
2 (50)	8.50 (216)	1.93 (49)	6.50 (165.1)	3.88 (98.4)	-	3.90 (100)	6.40 (162.56)	-	11.80 (300)	65 (30)
3 (80)	11.13 (283)	2.91 (74)	8.25 (209.6)	5.38 (136.3)	-	8.30 (210)	6.40 (162.56)	-	18.10 (460)	122 (55)
4 (100)	12.00 (305)	3.94 (100)	10.00 (254)	6.19 (157.2)	-	10.00 (254)	7.10 (180.34)	-	18.10 (460)	202 (92)
6 (150)	15.88 (403)	5.91 (150)	12.50 (317.5)	7.00 (177.8)	7.90 (200)	12.50 (317.5)	10.90 (277)	11.94 (303.2)	15.70 (400)	447 (203)
8 (200)	19.75 (502)	7.91 (201)	15.00 (381)	8.75 (222.3)	9.10 (230)	15.20 (385)	14.10 (358)	11.94 (303.2)	15.70 (400)	785 (357)
10 (250)	22.38 (568)	9.92 (252)	17.50 (444.5)	11.25 (285.8)	11.60 (295)	18.50 (470)	16.20 (412)	14.63 (371.5)	23.60 (600)	1115 (507)
12 (300)	25.50 (648)	11.93 (303)	20.50 (520.7)	12.63 (320.7)	13.00 (330)	21.30 (540)	18.20 (462)	14.63 (371.5)	27.60 (700)	1622 (737)
14 (350)	30.00 (762)	13.15 (334)	23.00 (584.2)	15.70 (400)	15.30 (388)	25.10 (638)	18.50 (470)	20.40 (518)	23.60 (600)	1890 (859)
16 (400)	33.00 (838)	15.16 (385)	25.50 (647.7)	16.70 (423)	16.70 (423)	28.00 (710)	19.40 (493)	22.60 (575)	27.60 (700)	2650 (1205)
18 (450)	36.00 (914)	17.17 (436)	28.00 (711)	19.20 (488)	19.60 (498)	32.30 (820)	22.40 (569)	22.60 (575)	27.60 (700)	3502 (1592)
20 (500)	39.00 (991)	19.17 (487)	30.50 (774.7)	21.20 (538)	21.60 (549)	34.40 (874)	24.70 (627)	23.30 (592)	31.50 (800)	4829 (2195)
24 (600)	45.00 (1143)	21.18 (539)	36.00 (914)	24.60 (624)	23.40 (594)	40.90 (1040)	29.30 (744)	27.30 (693)	35.40 (900)	7612 (3460)

- Notes:
1. Ball Diameter Dimensions (B) are per API 6D design convention for full port valves.
 2. Additional materials and design configurations available. Please contact factory.

Dimensions

Trunnion Design • 2 thru 24 NPS • ASME Class 600

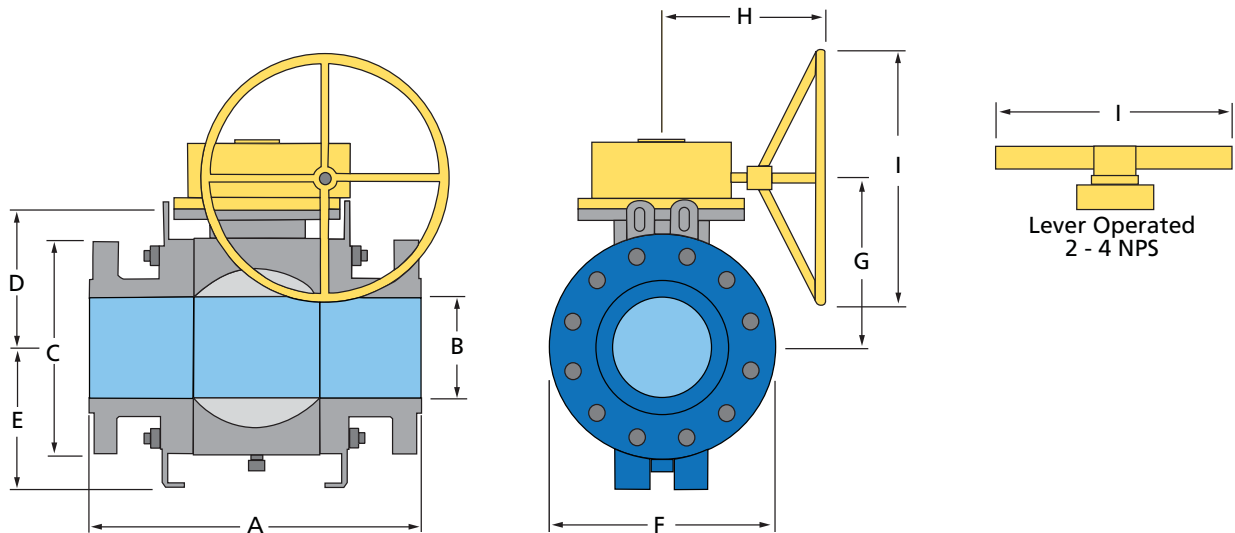

Class 600 - Dimensions in Inches (mm)

Size NPS (DN)	A	B	C	D	E	F	G	H	I	Weight LB (KG)
2 (50)	11.50 (292)	1.93 (49)	6.50 (165.1)	6.10 (155)	-	6.50 (165)	6.40 (162.56)	-	23.60 (600)	99 (45)
3 (80)	14.00 (356)	2.91 (74)	8.25 (209.55)	6.70 (170)	-	9.00 (229)	6.40 (162.56)	-	27.55 (700)	176 (80)
4 (100)	17.00 (432)	3.94 (100)	10.75 (273.05)	8.00 (201)	-	10.40 (264)	7.10 (180.34)	-	33.70 (857)	308 (140)
6 (150)	22.00 (559)	5.91 (150)	14.00 (356)	9.10 (230)	9.20 (234.5)	12.60 (319)	11.50 (292)	11.94 (303.2)	15.70 (400)	557 (253)
8 (200)	26.00 (660)	7.91 (201)	16.50 (419.1)	11.40 (290.5)	12.40 (316)	17.00 (432)	14.30 (363)	11.94 (303.2)	19.70 (500)	1067 (485)
10 (250)	31.00 (787)	9.92 (252)	20.00 (508)	13.00 (329)	15.70 (399)	20.40 (518)	16.50 (418.5)	14.63 (371.5)	23.6 (600)	1668 (758)
12 (300)	33.00 (838)	11.93 (303)	22.00 (558.8)	15.90 (404.7)	17.80 (451)	24.50 (622)	18.20 (463)	14.63 (371.5)	27.6 (609.6)	2347 (1067)
14 (350)	35.00 (889)	13.15 (334)	23.75 (603.25)	15.70 (400)	15.30 (388.5)	25.10 (638)	18.50 (470)	20.40 (518)	23.60 (600)	2383 (1083)
16 (400)	39.00 (991)	15.16 (385)	27.00 (686)	17.40 (443)	17.60 (445.8)	28.90 (735)	19.40 (493)	22.60 (575)	27.60 (700)	3355 (1525)
18 (450)	43.00 (1092)	17.17 (436)	29.30 (743)	19.60 (498)	20.10 (510.5)	33.10 (840)	22.40 (569)	22.60 (575)	27.60 (700)	4609 (2095)
20 (500)	47.00 (1194)	19.17 (487)	32.00 (812.8)	22.20 (565)	21.30 (542)	36.20 (920)	24.70 (627)	23.30 (592)	31.50 (800)	5804 (2638)
24 (600)	55.00 (1397)	21.18 (589)	37.00 (940)	24.60 (624.5)	23.50 (596)	41.10 (1045)	29.30 (744)	27.30 (693)	35.40 (900)	10419 (4736)

- Notes:
1. Ball Diameter Dimensions (B) are per API 6D design convention for full port valves.
 2. Additional materials and design configurations available. Please contact factory.

QuadroSphere® Model Numbers

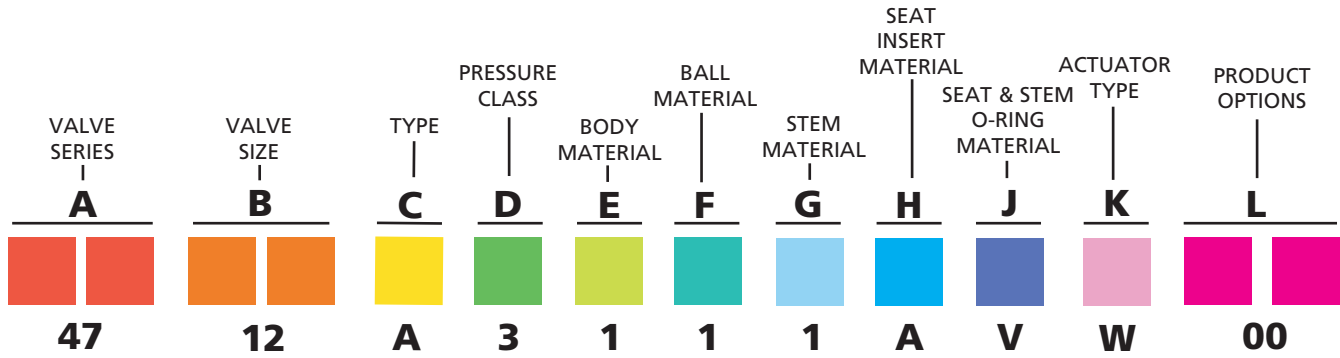

Example: 12 NPS Flanged, Trunnion, 3 Piece, Full Bore Ball Valve, Class 300, Carbon Steel A105 body, T316 stainless steel ball/HC, T316 Stainless Steel Stem, RPTFE Seat Insert, Viton® O-Ring, with a Worm Gear actuator.

A	VALVE SERIES	F	BALL MATERIAL cont'd
4700 - QuadroSphere® Ball Valve		8 - Stainless Steel 410/HC C - SS316L/HC 9 - T316 Stainless Steel/TCC D - SS316/Stellite #6 A - Stainless Steel 410/TCC E - LF2/TCC B - SS316L/TCC F - A105/TCC	
B	SIZE	G	STEM MATERIAL
Sizes shown in NPS (DN) 2 (50) 8 (200) 16 (400) 3 (80) 10 (250) 18 (450) 4 (100) 12 (300) 20 (500) 6 (150) 14 (350) 24 (600)		1 - T316 SS 5 - Monel, K500 9 - LF2/ENP 2 - T410 SS 6 - Inconel, 625 A - SS316L 3 - T420 SS 7 - F51 SS 4 - 17-4 PH 8 - A105/ENP	
C	TYPE	H	SEAT INSERT MATERIAL
A - RF Flanged, Trunnion, 3 Piece, Full Port B - Butt Weld, Trunnion, 3 Piece, Full Port C - RTJ Flanged, Trunnion, 3 Piece, Full Port D - RF Flanged, Trunnion, 3 Piece, Reduced Port E - RTJ Flanged, Trunnion, 3 Piece, Reduced Port S - Socket Weld, Trunnion, 3 Piece, Full Port T - Threaded, Trunnion, 3 Piece, Full Port		A - RPTFE F - Metal Seat/Stellite #6 B - Devlon® G - Metal Seat/TCC C - PEEK H - PCTFE/KEL-F D - Delrin J - 30% Carbon Fiber Filled PEEK E - Nylon K - TFM 1600 L - Metal Seat/Stellite #21	
D	ASME PRESSURE CLASS	J	SEAT & STEM O-RING MATERIAL
1 - 150 9 - 900 3 - 300 A - 1500 6 - 600 B - 2500		V - Viton® B - Buna-N A - Aflas® D - Viton® AED M - Markez® H - HNBR E - EPDM HT 550°F F - FF200 K - Kalrez® J - E0962-90 EPDM G - Graphite L - FF400 C - Chemraz® N - Parker FF580	
E	BODY MATERIAL	K	ACTUATOR TYPE
1 - Carbon Steel, A105 6 - T316L Stainless Steel, F316L 2 - Carbon Steel, LF2 3 - T316 Stainless Steel, F316 4 - Carbon Steel, LCB 5 - T316L Stainless Steel		B - Bare Stem M - Motor Actuator H - Hydraulic Actuator P - Pneumatic Actuator L - Lever W - Worm Gear	
F	BALL MATERIAL	L	PRODUCT OPTIONS
1 - T316 Stainless Steel, F316/ Hard Chrome Plated (HC) 2 - Carbon Steel, A105 / HC 3 - Carbon Steel, LF2 / HC 4 - Carbon Steel, LCB / HC 5 - Stainless Steel, F51 / HC 6 - Carbon Steel, A105/ENP 7 - Carbon Steel, LF2/ENP		00 - Standard Construction XX - Factory Designation for options, i.e.: Special Coatings Double Piston Effect Seats Ring Master® Seating System Special Testing	

SCOPE

- 1.1 This specification covers the design, manufacture, and testing of QuadroSphere® Trunnion Mounted Full Port Ball Valves furnished in sizes NPS 2 to 24, in ASME Pressure Classes 150 thru 2500.

SPECIFIC DESIGN CONSIDERATIONS

- 2.1 Valve to incorporate QuadroSphere® high integrity ball element to promote self-flushing feature and minimize seat wear.
- 2.2 Valve ball element to be relieved on top and bottom adjacent to trunnions to minimize seat and ball element engagement and promote self-flushing feature.
- 2.3 Valve ball element to be truncated on upstream and downstream ends to minimize seat and ball element engagement.
- 2.4 Ball engagement with seat shall be less than that of standard spherical ball during interim valve travel to promote sealing integrity.
- 2.5 Geometry of ball element shall allow (5) separate and distinct flow paths to maximize efficiency of flow during interim valve travel.
- 2.6 Valve seat and ball contact shall be minimized during interim travel such that minimal contact exists between ball and seat.
- 2.7 Valve seat and ball contact shall be reduced to four (4) independent line contact points on each seat during interim valve travel.

OTHER DESIGN CONSIDERATIONS

- 3.1 Valve to be trunnion mounted design to provide bi-directional sealing and to reduce running torque.
- 3.2 Valve ball to be 316 Stainless Steel with Hard Chrome applied as minimum standard.
- 3.3 Valve seats and stem to be 316 Stainless Steel construction as minimum standard.
- 3.4 Valve seats shall be a spring loaded/pressure energized design. They shall have an insert with a secondary metal seat back up.
- 3.5 The stem shall be anti-blowout design with anti-static devices.
- 3.6 NPS 4 valves and smaller to have drain, vent, and stem injection ports.
- 3.7 NPS 6 valves and larger to have drain, vent, stem, and two seat injection ports.
- 3.8 Valve shall incorporate double block and bleed sealing design (DBB).
- 3.9 Valve shall be capable of bi-directional flow.
- 3.10 Valve shall be capable of bi-directional shut-off.
- 3.11 Valve shall exhibit zero leakage per section 11 of API 6D.
- 3.12 Valve seat assemblies shall be field replaceable.
- 3.13 Valve body and ball shall be forged material.

STANDARDS AND APPROVALS

- 4.1 Valve to be manufactured per ASME B16.34 & API 6D.
- 4.2 Valve to carry API 6D Monogram.
- 4.3 Valve face-to-face dimensions to be per API 6D.
- 4.4 Valve Flanged end dimensions to be per ASME B16.5.
- 4.5 Valve Butt Weld end dimensions to be per ASME B31.4.

- 4.6 Valve to be available in anti-static and Fire-Safe design to API 607.
- 4.7 Valve top works shall have ISO 5211 compliant mounting pad.
- 4.8 Valve bolting material shall conform to be ASME B16.34.
- 4.9 Valve shall be permanently marked in accordance with API 6D. Valve shall not be marked on the flanges.
- 4.10 Manufacturer shall have a quality management system that is certified to ISO 9001 by an accredited, certifying body.
- 4.11 Valve shall meet Fugitive Emission Standard ISO-15848-2.

ACTUATION

- 5.1 Manual, electric or pneumatic actuation shall be provided as specified.
- 5.2 Lever handles are available for certain valve sizes and pressure classes. Consult factory.
- 5.3 Manual actuators shall be of the worm and gear design with externally adjustable stops. Actuators shall be lubricated and fully enclosed against the entry of water.
- 5.4 Pneumatic actuators shall be provided as specified.
- 5.5 Electric actuators shall be provided as specified.
- 5.6 Other types of actuation shall be provided as specified.

OPTIONS

- 6.1 Seating surface options are available for the ball and metal seats: Stellite, Electroless Nickel Plating, Tungsten Carbide Coating
- 6.2 Seat materials include: RPTFE, PEEK, Nylon, Devlon® Carbon Fiber Filled PEEK, Graphite and Metal.
- 6.3 Seal materials include: Aflas®, HNBR, Kalrez®, Chemraz®, Markez®, Viton®, Viton® AED and FF200.
- 6.4 NACE compliant trims are as specified for special services.
- 6.5 Double piston effect seating available on one or both ends (DIB).
- 6.6 Special coatings for the exterior and interior of the valve are available per application.
- 6.7 On NPS 6 and larger sizes for high solids service, a Ring Master® seating system shall be provided.

MANUFACTURE

- 7.1 Valve exteriors on carbon steel valves shall be coated with a rust inhibiting coating.
- 7.2 Valve shall be seat and shell tested in accordance with API 6D requirements.
- 7.3 Valve shall be cycle tested and stops set for manual, pneumatic or electric actuators.
- 7.4 QuadroSphere® Ball Valve shall be Val-Matic Model 4700, Trunnion Mounted Full Port Ball Valve as manufactured by Val-Matic® Valve & Mfg. Corporation, Elmhurst, IL. USA or approved equal.



Val-Matic's quality of design and meticulous workmanship has set the standards by which all others are measured. Quality design features such as the AWWA **Ener-G® Ball Valve** with its energy efficient design, fusion bonded epoxy and adjustable resilient seating....**Cam-Centric® Plug Valves** have more requested features than any other eccentric plug valve....**American-BFV® Butterfly Valves** include a field replaceable seat without the need for special tools....**Tilted Disc® Check Valves** with high strength and wear resistant aluminum bronze trim as standard....**Silent Check Valves** featuring combined resilient/metal-to-metal seating and are **NSF/ANSI 61 & 372 Certified**....**Sure Seal Foot Valves** provided with a heavy duty stainless steel screened inlet....**Swing-Flex® and Surgebuster® Check Valves** designed with an unrestricted full flow area....**Swing Check Valves** with field adjustable closure

versatility....**Dual Disc® Check Valves** utilizing stabilized components to provide extended life....**Air Release, Air/Vacuum and Combination Air Valves** provided standard with Type 316 stainless steel trim....**VaultSafe®** family of products includes the **FloodSafe® Inflow Preventer, FrostSafe®** two-way damper and the **VentSafe®** vent pipe security cage. The **QuadroSphere® Trunnion Ball Valve** features a unique ball design with recessed surfaces creating additional flow paths to provide a self-cleaning action and reduced wear and torque.

Val-Matic is totally committed to providing the highest quality valves and outstanding service to our customers. Complete customer satisfaction is our goal. **Make the change to quality, specify Val-Matic!**

VAL-MATIC® *Your Valve Experts™*

Val-Matic Valve and Manufacturing Corp.
 905 Riverside Drive, Elmhurst, IL 60126
 Phone: 630-941-7600 • Fax: 630-941-8042
 www.valmatic.com • valves@valmatic.com

Copyright © 2017 Val-Matic Valve & Mfg. Corp. 12/17
 ISO 9001:2008 certified company